

Assistant Mason

(Job Role)

(Qualification Pack: Ref. Id. CON/Q0102)

Sector : Construction

Textbook for Class IX



विद्यया ऽ मृतमश्नुते



एन सी ई आर टी
NCERT

राष्ट्रीय शैक्षिक अनुसंधान और प्रशिक्षण परिषद्
NATIONAL COUNCIL OF EDUCATIONAL RESEARCH AND TRAINING

ISBN 978-93-5292-329-8

ALL RIGHTS RESERVED

- ❑ No part of this publication may be reproduced, stored in a retrieval system or transmitted, in any form or by any means, electronic, mechanical, photocopying, recording or otherwise without the prior permission of the publisher.
- ❑ This book is sold subject to the condition that it shall not, by way of trade, be lent, re-sold, hired out or otherwise disposed of without the publisher's consent, in any form of binding or cover other than that in which it is published.
- ❑ The correct price of this publication is the price printed on this page, Any revised price indicated by a rubber stamp or by a sticker or by any other means is incorrect and should be unacceptable.

First Edition

July 2020 Shravana 1942

PD 5T SU

© **National Council of Educational Research and Training, 2020**

₹ **115.00**

OFFICES OF THE PUBLICATION

DIVISION, NCERT

NCERT Campus
Sri Aurobindo Marg
New Delhi 110 016 Phone : 011-26562708

108, 100 Feet Road
Hosdakere Halli Extension
Banashankari III Stage
Bengaluru 560 085 Phone : 080-26725740

Navjivan Trust Building
P.O.Navjivan
Ahmedabad 380 014 Phone : 079-27541446

CWC Campus
Opp. Dhankal Bus Stop
Panihati
Kolkata 700 114 Phone : 033-25530454

CWC Complex
Maligaon
Guwahati 781 021 Phone : 0361-2674869

Publication Team

Head, Publication Division : *Anup Kumar Rajput*

Chief Editor : *Shweta Uppal*

Chief Production Officer : *Arun Chitkara*

Chief Business Manager : *Vipin Dewan*
(Incharge)

Production Officer : *Abdul Naim*

Cover and Layout

DTP Cell, Publication Division

Printed on 80 GSM paper with NCERT watermark

Published at the Publication Division by the Secretary, National Council of Educational Research and Training, Sri Aurobindo Marg, New Delhi 110 016 and printed at SG Print Packs Pvt. Ltd., F-478, Sector-63, Noida - 201 301 (U.P.)

FOREWORD

The National Curriculum Framework–2005 (NCF–2005) recommends bringing work and education into the domain of the curricular, infusing it in all areas of learning while giving it an identity of its own at relevant stages. It explains that work transforms knowledge into experience and generates important personal and social values such as self-reliance, creativity and cooperation. Through work one learns to find one’s place in the society. It is an educational activity with an inherent potential for inclusion. Therefore, an experience of involvement in productive work in an educational setting will make one appreciate the worth of social life and what is valued and appreciated in society. Work involves interaction with material or other people (mostly both), thus creating a deeper comprehension and increased practical knowledge of natural substances and social relationships.

Through work and education, school knowledge can be easily linked to learners’ life outside the school. This also makes a departure from the legacy of bookish learning and bridges the gap between the school, home, community and the workplace. The NCF–2005 also emphasises on Vocational Education and Training (VET) for all those children who wish to acquire additional skills and/or seek livelihood through vocational education after either discontinuing or completing their school education. VET is expected to provide a ‘preferred and dignified’ choice rather than a terminal or ‘last-resort’ option.

As a follow-up of this, NCERT has attempted to infuse work across the subject areas and also contributed in the development of the National Skill Qualification Framework (NSQF) for the country, which was notified on 27 December 2013. It is a quality assurance framework that organises all qualifications according to levels of knowledge, skills and attitude. These levels, graded from one to ten, are defined in terms of learning outcomes, which the learner must possess regardless of whether they are obtained through formal, non-formal or informal learning. The NSQF sets common principles and guidelines for a nationally recognised qualification system covering Schools, Vocational Education and Training Institutions, Technical Education Institutions, Colleges and Universities.

It is under this backdrop that Pandit Sunderlal Sharma Central Institute of Vocational Education (PSSCIVE), Bhopal, a constituent of NCERT has developed learning outcomes based modular curricula for the vocational subjects from Classes IX to XII. This has been developed under the Centrally Sponsored Scheme of Vocationalisation of Secondary and Higher Secondary Education of the Ministry of Human Resource Development.

This textbook has been developed as per the learning outcomes based curriculum, keeping in view the National Occupational Standards (NOS) for the job role and to promote experiential learning related to the vocation. This will enable the students to acquire necessary skills, knowledge and attitude.

I acknowledge the contribution of the development team, reviewers and all the institutions and organisations, which have supported in the development of this textbook.

NCERT would welcome suggestions from students, teachers and parents, which would help us to further improve the quality of the material in subsequent editions.

New Delhi
January 2018

HRUSHIKESH SENAPATY
Director
National Council of Educational
Research and Training

ABOUT THE TEXTBOOK

The construction sector in India is considered to be the second largest employer and contributor to economic activity, after the agriculture sector. This sector employs more than 44.08 million people in the country. Around 50 per cent of the demand for construction activities in India comes from the infrastructure sector, while the rest comes from industrial activities, residential and commercial development, etc. The construction industry accounts for about 11 per cent of India's GDP. The Planning Commission estimates that the construction sector will require another 47 million people in the workforce over the next decade.

There is a need for formal training for construction workers. This book contains sessions for imparting knowledge and skills on various aspects of the construction technology. It also includes information, exercises and assessment activities.

This textbook has been developed with the expertise of the vocational teachers, industry experts and academicians for making it a useful and inspiring teaching-learning resource material for the vocational students. Adequate care has been taken to align the content of the textbook with the National Occupational Standards (NOS) for the job role so that the student acquires the necessary knowledge and skills as per performance criteria mentioned in the respective NOS of the Qualification Pack (QP). The NOS for the job role of 'Assistant Mason' covered through this textbook are as follows:

1. CON/N0101: erect and dismantle temporary scaffold of 3.6 meter height
2. CON/N0105: handle and use hand and power tools related to masonry work
3. CON/N0106: assist in tiling, stone laying and concrete masonry works
4. CON/N0107: assist in brick or block work including fixing doors and windows and plastering works
5. CON/N8001: work effectively in a team to deliver desired results at the workplace
6. CON/N9001: work according to personal health, safety and environment protocol on construction site

Unit 1 of the textbook gives introduction to the building structure. Unit 2 focusses on building material. Unit 3 deals with units of measurement used in civil works. Unit 4 is on handling of basic masonry tools. Unit 5 deals with the marking of lines. Unit 6 explains the building drawing and Unit 7 discusses about the foundation works.

Saurabh Prakash

Professor

Department of Engineering and Technology

PSSCIVE, Bhopal

© NCERT
not to be republished

TEXTBOOK DEVELOPMENT TEAM

MEMBERS

Abhay Kumar Jha, *Engineer* and *Head*, Department of Civil Engineering LNCTS, Bhopal

Aslam Nadaf, *Vocational Instructor*– Construction, Govt. High School, Pernem, Goa

Avinash Singh, *Consultant*, PSSCIVE, Bhopal

Hemant Wadikar, *Engineer* and *Lecturer*, Building Maintenance, Swami Vivekanand Jr. College (HSC Vocational) Sindhi Society, Chembur, Mumbai

Tapas Singh, *Engineer* and *Assistant Professor*, Department of Civil Engineering, TITE, Bhopal

MEMBER-COORDINATOR

Saurabh Prakash, *Professor*, Department of Engineering and Technology, PSSCIVE, Bhopal

© NCEPT
not to be republished

ACKNOWLEDGEMENTS

The National Council of Educational Research and Training (NCERT) expresses its gratitude to all members of the Project Approval Board (PAB) and officials of the Ministry of Human Resource Development (MHRD), Government of India, for their cooperation in the development of this textbook. The Council also extends gratitude to all the contributors for sharing their expertise and valuable time by positively responding to the request for the development of this textbook. The Council expresses its gratitude towards Rajesh Khambayat, *Joint Director*, PSSCIVE, Bhopal, for providing support and guidance in the development of this textbook. The contribution of our textbook review committee member, Gagan Gupta, *Professor*, NCERT, New Delhi, is also duly acknowledged. We are thankful to Saurabh Prakash *Professor*, Department of Engineering and Technology, PSSCIVE, NCERT, Bhopal, for providing photographs used in the textbook. The images used other than these are under Creative Commons License. Avinash Singh, *Former Consultant*, Department of Engineering and Technology, PSSCIVE, Bhopal, is also duly acknowledged for his contribution in the development of this textbook for vocational skills. The Council is grateful to Saroj Yadav, *Professor and Dean (Academic)*, NCERT, and Ranjana Arora, *Professor and Head*, Department of Curriculum Studies, for evaluating and giving suggestions for the improvement of this book and its finalisation.

The Council also acknowledges the copyediting and valuable contribution of Shveta Uppal, *Chief Editor* and Shilpa Mohan, *Assistant Editor (Contractual)* in shaping this book. The efforts of Pawan Kumar Barriar, *DTP Operator*, and Junaid Ahmed, *DTP Operator (Contractual)*, Publication Division, NCERT; Akhilesh Kashiv, *Computer Operator*, Vikas Kumar Koge, *Graphic Artist (Contractual)*, and Pinki Tiwari, *Graphic Designer (Contractual)*, PSSCIVE, NCERT, for flawless layout design are also acknowledged. The Council is also grateful to the Construction Skill Development Council of India (CSDC), New Delhi for its support.

CONTENTS

<i>Foreword</i>	<i>iii</i>
<i>About the Textbook</i>	<i>v</i>
Unit 1: Introduction to the Building Structure	1
Unit 2: Building Material	5
Session 1: Stones	5
Session 2: Clay Products (Bricks, Tiles and Terracotta)	9
Session 3: Cement and Lime	17
Session 4: Ferrous and Non-ferrous Metals	21
Session 5: Mortar and Concrete	26
Session 6: Building Finishing Material	35
Session 7: Miscellaneous Materials	45
Unit 3: Units of Measurements used in Civil Works	55
Unit 4: Handling of Basic Masonry Tools	65
Unit 5: Marking of Line	71
Unit 6: Building Drawing	74
Session 1: Basic Geometric Constructions	74
Session 2: Tools of Engineering Drawing	87
Session 3: Building and Building Drawing	101
Unit 7: Foundation Works	105
Session 1: Excavation	107
Session 2: Construct Spread Footing Foundation	110
<i>Answer Key</i>	<i>112</i>
<i>Glossary</i>	<i>116</i>
<i>Bibliography</i>	<i>118</i>

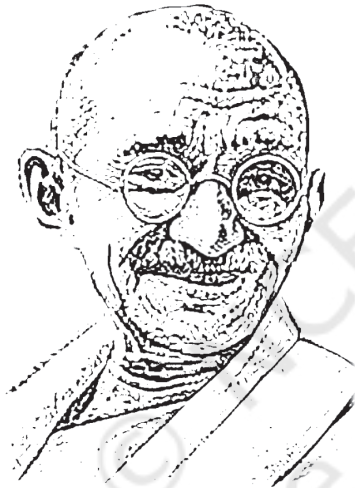

*I am uncompromising
in the matter of
woman's rights. In
my opinion, she
should labour under
no legal disability not
suffered by man. I
should treat the
daughters and sons
on a footing of perfect
equality.*

Unit



Introduction to the Building Structure

All of us live in different kinds of buildings. Notice how each building has a different form — house, school, shopping mall, picture hall, hostel, hospital, cricket stadium, office, etc. Buildings serve various needs of the society — primarily as shelter from weather, security, living space, privacy, to store belongings and to comfortably live and work.

Hence, we can conclude that a building is a man-made structure with a roof and walls standing more or less permanently in one place.

Buildings come in a variety of shapes, sizes and functions. A building structure consists of two parts — superstructure and substructure. A structure constructed above the plinth level is termed as a *super structure* and a structure constructed below the ground level is termed as a *sub-structure*.

Following are the elements (Fig.1.1) of building structures:

- (i) Foundation
- (ii) Plinth
- (iii) Roof
- (iv) Wall
- (v) Floor
- (vi) Doors and windows



17922CH01

- (vii) Staircases
- (viii) Arches and Lintels



Fig:1.1: Typical Section of Building Showing Different Elements

Now that we have familiarised ourselves with the various elements of a building structure from the above drawing, let us understand what each of them mean.

(a) Foundation: bears the total load of the structure and transfers it to the hard soil strata. In this type of structure, the foundation provides stability to the structure.

(b) Plinth: is the portion between the super structure and sub-structure. It is a horizontal finished level above ground level which consists of earth filling, rubble soling, Plain Cement Concrete (PCC), etc.

(c) Wall: is the structure that demarcates an area from another area and encloses sides of a room. They provide privacy and safety. Walls also divide the structure into parts, generally called rooms.

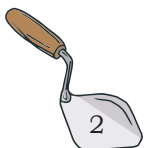

(d) Floor: is a horizontal part of the superstructure constructed on the ground. A well-constructed floor enables easy and smooth movement. For ground floor, the top surface of plinth is covered with hard finishing material like cement, mosaic or tiles.

(e) Roof: is a part that is built on top of the structure. It protects the structure from different weather conditions. It also acts as a partition between vertical floors. Reinforced Cement Concrete (RCC) slab is also used for making roofs and consists of cement concrete and adequate steel bars.

(f) Staircase: is a sequence of stairs or steps and it is provided to afford the means of ascent and descent between floors and landings.

(g) Arches and Lintels: an arch is a structure that is a pillar, post, or wall. Whereas, a lintel is a beam or support at the top of a door or window, that carries the weight of a structure.

Practical Activity

Activity 1

Visit a school building and identify the different building components and draw them.

Material required

Writing material and a scale

Procedure

- Visit a school building site
- Identify the components of the building and make a list
- Draw the figures of building components

Check Your Progress

A. Short answer questions

1. List the components of a building structure.
2. Differentiate between super-structure and substructure components of a building.
3. Explain the importance of foundation and roof.

B. Fill in the blanks

1. _____ is the lowermost part of the building.
2. _____ encloses the sides of a room.

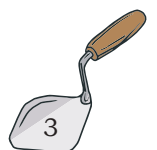

NOTES

3. _____ is a portion between the super structure and the sub-structure.
4. A building structure consists of two parts _____ and a sub-structure.

C. Define

1. Plinth
2. Wall

D. Multiple choice questions

1. Construction of _____ is to protect the structure from rain.
(a) lintel (b) arch
(c) roof (d) wall
2. Structure constructed above the plinth level is termed as _____.
(a) superstructure (b) wall
(c) sub-structure (d) foundation
3. The function of a wall is to provide _____.
(a) privacy (b) partition
(c) approach to next room (d) (a) and (b) Both.
4. Which of the following is not an element of a building?
(a) foundation (b) plinth
(c) wall (d) soil
5. For the smooth movement of people we construct _____ horizontally.
(a) wall (b) roof
(c) beam (d) floor
6. Landing is always constructed with a _____.
(a) wall (b) arches
(c) lintels (d) staircase

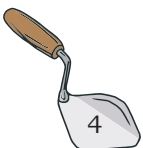

Unit 2



Building Material

Have you ever thought how buildings are made and what are the different components of a building. You must have seen different building materials near a construction site. Buildings are made of various type of material. Do you know that in the total expenditure in the construction of a structure, the building material share around 60–65 per cent cost. We will now try to familiarise ourselves with different building material as well as their composition.



17922CH02

Important building material used in construction are:

- (i) Stones
- (ii) Clay Products (Bricks, Tiles and Terracotta)
- (iii) Cement
- (iv) Lime
- (v) Ferrous Metals and Non-ferrous Metals
- (vi) Steel
- (vii) Mortar and Concrete
- (viii) Building Finishing Materials
- (ix) Miscellaneous Materials

SESSION 1: STONES

1. Stones

Stone is a natural material obtained from rocks. The stones which are used for construction of various

NOTES

structures are known as building stones. There are different types of rocks and stones (Fig. 2.1) The occurrence and characteristics of these stones vary. Some often used stone forms are granite, gneiss, marble, basalt, slate, sandstone, limestone, *kankar*, laterite, quartzite, chalk, compact limestone, serpentine, etc.

Uses of stones

Stones are widely used in the form of—

1. blocks in the construction of buildings, lintels, arches, walls, columns, abutments and piers of bridges, etc.
2. stone ballast (broken stone) for railway track, road construction, preparation of cement concrete mixture for foundation in the form of coarse aggregates, flooring, artificial stones and reinforced cement concrete.

Characteristics of good building stones

1. Appearance: good building stone would have a uniform colour, would be free from clay holes, bands or colour spots.

2. Strength: sturdy building stones should be able to withstand compression as the stones used in building construction are generally subjected to compressive strength. Compressive strength is the capacity of material or structure to resist or withstand breaking under high pressure. Generally, compressive strength of building stone varies from 60 to 200 Newton per square mm.

3. Structure: a good building stone has uniformity of texture. It should be either closed grained or crystalline and free from cavities and cracks also.

4. Hardness: the hardness of certain stones may define their durability. The coefficient of hardness should be more than 14. It should be able to resist the abrasive forces caused due to wear and friction.

5. Heaviness: the stones of heavier varieties are more compact, less porous and have greater specific gravities.

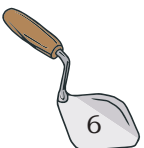

The specific gravity of good building stones ranges between 2.4 to 2.8.

NOTES



Fig.2.1: Different types of stones

6. Toughness: a stone's toughness is assessed by its ability to withstand stresses developed due to vibrations of moving loads applied over it.

7. Durability: good building stones should be able to resist various atmospheric actions, such as extreme temperatures, wind, rain, etc. The effect of atmospheric conditions on stones is known as weathering. Stones with such properties would be more useful in construction work.



NOTES

8. Seasoning: the amount of moisture contained in freshly quarried stones is known as quarry sap. This makes the stones softer and easier to work with.

9. Dressing: the art of converting a natural stone into definite shape is known as dressing. Stones should have good dressing properties, i.e. be easily workable.

10. Porosity and absorption: very porous stones are not suitable for construction works. A good building stone should not be porous and should not absorb water when immersed.

11. Resistance to fire: stones should be able to resist high temperature and should be resistance to fire.

12. Availability: the stone should be easily and economically available.

Practical Activity

Activity 1

Visit a stone market and collect samples of different types of stones used for building and identify them

Material required

Writing material and a scale

Procedure

1. Identify a construction stone selling shop.
2. Select various types of stones available in the shop.
3. Interact with your teacher and identify the different types of stones.
4. Discuss the properties of these stones.

Activity 2

Visit a stone quarry, observe the activities there and prepare a report.

Material required

Writing material and a scale

Procedure

1. Visit a stone quarry.
2. Interact with your teacher to understand the process and activities being undertaken at the site.
3. Make a report of your observations at the site.

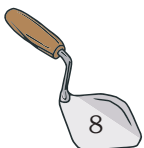

Check Your Progress

NOTES

A. Write short notes on

1. Use of stone in building construction
2. Characteristics of good building stones
3. Types of stone used in construction

B. Fill in the blanks

1. Stones are used in the form of _____ in the construction of buildings.
2. _____ is obtained from rock.
3. Stones are resistant to _____.
4. The effect of atmospheric conditions on stones is known as _____.
5. The specific gravity of good building stones ranges between _____.

C. Multiple choice questions

1. The art of converting a natural stone into definite shape is known as _____.
(a) dressing (b) heaviness
(c) seasoning (d) good stone.
2. Good building stones should be able to resist various atmospheric actions like _____.
(a) temperature (b) wind
(c) rain (d) All of the these
3. The specific gravity of good building stones ranges _____.
(a) between 2.4 to 2.8 (b) more than 2.8
(c) less than 2.4 (d) None of these

SESSION 2: CLAY PRODUCTS (BRICKS, TILES AND TERRACOTTA)

Clay, silt and sand are the basic ingredients of earth. These are the natural substances produced as a result of weathering or disintegration of soft rocks. Clay contains considerable amount of particles smaller than or equal to 0.002 mm size. The materials which are made from clays or their compounds are called clay products. These are widely used as building materials. Bricks, tiles and terracotta are the commonly used clay products.

Bricks

They are the blocks of tamped clay moulded into suitable shapes and sizes and are extensively used as building material. Moulded bricks are first allowed to

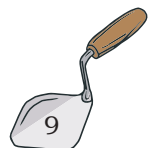

NOTES

dry and then burnt in kilns to make them strong, hard and durable. Generally, bricks are rectangular and length of the brick is equal to twice the width plus the thickness of mortar joint. The thickness of brick is less than or equal to the width of a brick.



Fig. 2.2: Bricks

Classification of bricks

Bricks may be broadly classified into two categories i.e., sun-dried or *kutch* bricks and burnt bricks or *pucca* bricks. *Kutch* bricks are made by sun drying of moulded clay mass. and *pucca* bricks are made by burning of sun-dried bricks in kilns. (Fig.2.2)

Size of bricks

As per the Bureau of Indian standards, New Delhi, the size of common clay bricks should be 19 cm × 9 cm × 9 cm. The brick size is taken as 20 cm × 10 cm × 10 cm with the mortar joint. However, if thinner bricks are required for specific purpose then they should be 19 cm × 9 cm × 4 cm without mortar thickness and 20cm × 10 cm × 5 cm with mortar joints. The minimum compressive strength of standard bricks should be 35 kg/cm².

Characteristics of good bricks

The characteristics of good bricks are that they

1. are rectangular in shape, compact in texture and uniform throughout with sharp edges.
2. are sound, hard, well-burnt and should have uniform red colour.

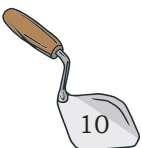

3. emit metallic ringing sound on striking with each other.
4. are free from holes, lumps, stones and particles of uncombined lime.
5. do not absorb more than 20 % water of their dry weight after 24 hours of immersion in normal water.
6. do not break when struck against another brick or when dropped flat from a height of about one metre on ground.
7. are be hard enough and finger nails may not be able to make any impression on their surface, when scratched.

It is necessary to conduct certain field tests of bricks so that proper bricks may be selected for construction works. Some of the field tests are summarised below.

Field testing of bricks

The shape and size of the bricks should be checked. Bricks should have truly rectangular faces and their size should be exactly the same as specified by BIS. All edges of bricks should be sharp and right angled. The soundness of bricks can be estimated by striking two bricks against each other or hammering by light hammer. The bricks should emit metallic ringing sound. The soundness of the bricks can also be field tested by dropping the bricks flat on the hard ground from a height of about one metre. The bricks should not break on dropping. The hardness of bricks can be estimated by scratching on the bricks with a finger nail. If no impression of nail scratch is left on bricks then these are considered to have sufficient hardness.

Tiles

Tiles are also clay products in the form of thin slabs. They are much thinner than the bricks and manufactured from a superior quality clay. Tiles are widely used for covering roofs, floor surfaces and for making drains. (Fig. 2.3)

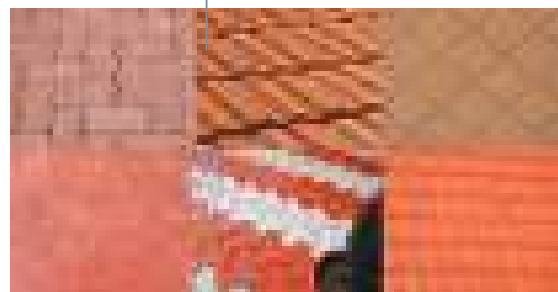

Fig.2.3: Different types of tiles

NOTES

Types of tiles

On the basis of the use, the tiles are mainly classified into three categories, viz., flooring tiles, roofing tiles, drain tiles.

Flooring tiles

These tiles are used for covering floor surfaces of buildings. They are either made of clay or concrete. Clay flooring tiles are made of even textured superior quality clay like china clay (Kaolin). This clay has pure white colour and it is refractory. Certain amount of sand (silica) is added in clay to minimise the shrinkage. Flooring tiles are usually thicker than the roofing tiles and their thickness varies from 15mm to 30mm. Similarly, their sizes may vary from 150mm×150mm to 300mm×300 mm. The commonly used tiles have sizes 150mm × 150 mm (6" × 6"), 150 mm × 75 mm (6" × 3") and 100mm×100mm (4" × 4") with 9 mm (3/8)" thickness. They may be of square, hexagonal or any other geometrical shapes. The tiles may also be coloured to achieve any desired shade. The top surface of flooring tiles is mostly glazed, whereas, the bottom surface is left unglazed to allow effective adhesion with surfaces.

General properties of flooring tiles

The flooring tiles should possess the following properties.

1. They should be of pleasant appearance.
2. They should be non-absorbent and easy to clean.
3. They should offer sufficient resistance to wear and tear, temperature and chemical action. They should be strong and durable.
4. They should be affordable, since they are used in a large quantity.
5. They should offer sufficient resistance against dampness in buildings to ensure healthy environment.

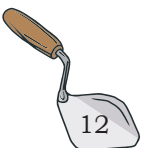

Types of flooring tiles

The flooring tiles are manufactured in different shapes, sizes and colours. Some of them are described below.

1. Sanitary tiles: are made up of dry mixture of fire clay and crushed stone. Generally, these are available in 150 mm x 150 mm size. They have glazed top surfaces and are used on floors and walls.

2. Mosaic tiles: are made up of cement concrete and their top surface is finished by using marble chips in cement mortar. Generally, they are made in 150 mm x 150 mm size. They may be prepared in beautiful colours and patterns.

3. Cement tiles: are rectangular in shape and their size is generally 150 mm x 150 mm. The top surface of these tiles is finished using pure cement. These tiles are used in chowks and verandah of low-cost houses. Precast paver blocks are commonly used nowadays for roadside sidewalls.

4. Porcelain tiles: are known as glazed tiles also. These are made of earth covered by a thorough glaze on the top surface. These are commonly used in bathrooms, water closets, kitchens, hospitals, sinks, etc.

5. Ceramic floor tiles: are made of clay, colouring and leaning agents. They are made in various shapes and sizes, such as square, rectangular, triangular and hexagonal, etc., with different colours. Ceramic tile floors are water proof, hard and resistance to wear, acid and alkalis.

6. Roofing tiles: are used to cover pitched roofs. They are manufactured in various shapes and sizes, for example, grooved, flat or ridged, etc. Clay roofing tiles are hard, durable and waterproof. and easy to maintain.

NOTES

General properties of roofing tiles

Roofing tiles should have the following properties.

1. The shape and size of roofing tiles should be such that the rainwater may be drained off from the roof.
2. These should be easily available and economical.
3. Roofing tiles should be well burnt, durable, and strong.
4. These should be non-conductor of heat.
5. These should provide decorative and pleasing appearance.

Types of roofing tiles

The roofing tiles are of different types and generally named according to their shapes and patterns. Some of the commonly used roofing tiles are described below.

1. Plain or flat tiles: are ordinary tiles having rectangular shape. Generally, they are manufactured in 250 mm × 150 mm to 280 mm × 180 mm sizes. Their thickness ranges from 10-17 mm. Plain tiles may have either continuous projection turned downwards at one end or may have two small nibs projecting downwards. These nibs help in the hanging of tiles on the glass of roof. The width and depth of nibs should not be less than 20 mm and 10 mm, respectively.



Fig.2.4: Allahabad Tiles

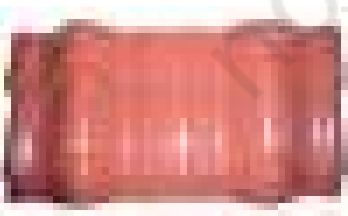
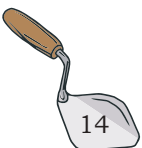

Fig.2.5: Mangalore Tiles

2. Allahabad tiles: consist of two sets of tiles. The lower tiles (under tile) are channel shaped flat tiles having upturned sides; whereas the upper tiles (over tiles) are semi-circular. The length of channel shaped part is kept 380 mm. The width of channel shaped tile at one end is kept 270 mm whereas, that on the other end is reduced to 230 mm. The pattern of these tiles is shown in Fig. 2.4. These tiles are fixed on ground work prepared by wooden battens on the roof slopes. Semi-circular tiles are moulded on a potter's wheel.

3. Mangalore tiles: are manufactured by moulding suitable clay under pressure. Mangalore tiles are flat pattern tiles with suitable key projections. They interlock at sides with each other and have a projecting



nib on the underside of top edge to rest against a batten. The arrangement of Mangalore tiles on a sloping roof is shown in Fig.2.5. These tiles are very strong, hard and classified in class 'A-A' and class 'A' categories. These tiles are generally available in three sizes.

4. Concrete tiles: are made using cement and aggregate (3 mm size) mixture. They are manufactured by machine moulding under pressure. The overall size of concrete tiles is 370 mm × 220 mm. These are more than 9 mm thick. These may be produced in various colours by adding desired pigments to suit the architectural requirements. They are becoming popular because of their uniform texture, high strength and good weather resistance properties.

Qualities of good tiles

Good tiles should have the following qualities.

1. They should be made of superior quality clay.
2. The shape and size should be true and regular.
3. They should be well burnt and possess uniform colour.
4. They should be free from wraps, cracks or flaws.
5. They should be hard, strong, sound and durable.

Terracotta

Terracotta is a kind of earthenware. It is generally used as substitute of stone in the ornamental parts of buildings. It is also a clay product burnt at very high temperatures. Good quality clay is required for manufacture of terracotta. Clay should have 5-8 % of iron oxide and about 1% lime. Crushed pottery, white sand and ground glass are also added in the clay to provide strength, rigidity and to check shrinkage while drying. (Fig.2.6)



Fig.2.6: Terracotta

Properties of good terracotta

1. It is a light, strong and durable material.
2. It is dense and uniform textured.
3. It is not affected by atmosphere agencies and acids.

- It is cheaper than finely dressed stone and can be cleaned easily.
- It can be manufactured in desired colours and patterns.
- It is fire proof.



Fig. 2.7: Terracotta wall tiles

Uses of terracotta

Terracotta is used as a substitute of stone for all types of ornamental works. Hollow terracotta blocks are used for various ornamental works like masonry facing, cornices, arches, fire-proof casing of steel columns and beams, etc.

Practical Activity

- Visit a market and collect the samples of different types of tiles.
- Identify good quality clay.
- Carry out different field tests of bricks.
- Visit a brick or a tile manufacturing unit and prepare a report of your observations.

Check Your Progress

A. Fill in the blanks

- Brick size is generally _____ × _____ × _____.
- Terracotta is used as _____ of stone.
- Concrete tiles are made using _____ and aggregate mixture.
- Mangalore tiles are flat _____ tiles with suitable key projections.
- Roofing tiles are used to _____ pitched roofs.
- Flooring tiles are used for _____ floor surfaces of buildings.

B. Write short notes on

- Uses of brick
- Mangalore tiles
- Properties of tiles
- Uses of tiles
- Testing of bricks

C. Multiple choice questions

- Good quality clay, which is required for manufacture of terracotta, should have iron oxide _____.

(a) 5 to 8 %	(b) more than 8%
(c) less than 5 %	(d) 6 to 9%

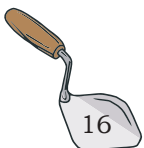

2. The minimum compressive strength of standard bricks should be _____.
(a) 32 kg/cm² (b) 35 kg/cm²
(c) 37.5 kg/cm² (d) 36.5 kg/cm²
3. Natural substances like clay, silt and sand are produced as result of _____ of soft rocks.
(a) destruction (b) erosion
(c) weathering (d) None of these
4. In manufacturing of flooring tiles certain amount of sand (silica) is added in clay to minimise the _____.
(a) bulk age (b) shrinkage
(c) compactness (d) conciseness
5. The soundness of the bricks can be tested by dropping the bricks flat on the hard ground from a height of _____.
(a) 1 m. (b) 1.5 to 1.8 m
(c) 0.5 m (d) more than 2 m

SESSION 3: CEMENT AND LIME

Cement

It is the basic binding material widely used in construction works. It is used for preparation of mortars and cement concrete. Cement has two forms—natural or artificial.

Natural cement

This type of cement was used in olden days before introduction of artificial cement. Nowadays, its use has become obsolete. Natural cement is achieved by burning and crushing the natural stones.

Artificial cement

It is manufactured artificially by burning mixture of argillaceous, siliceous and calcareous substances at high temperatures and then grinding the burnt mixture to fine powder. The burnt mixture of argillaceous and calcareous matter is called clinker. Little quantity of gypsum is also added in clinker before grinding to



Fig.2.8: Cement

control the rate of setting of cement. This is widely used because of the following advantages —

1. This can be manufactured in desired colours.
2. The setting rate, hardening rate and heat evolution of this cement can be regulated.
3. It can be manufactured in large quantities. There are many types of artificial cements, such as Portland cement, rapid hardening cement, quick setting cement and low heat cement, etc.



Fig.2.9: Cement with trowel

Composition of ordinary cement

Main raw materials used for manufacturing of cement are lime, silica and alumina (clay). Gypsum is also added in small proportion in order to control the setting rate of cement. Apart from these ingredients, most of the cement contain small amount of ferrous oxide, magnesium oxide, sulphur trioxide, alkalies and other materials

Properties of cement

To control the quality of cement, a standard is maintained. Important properties of cement are given below.

1. **Density:** is the ratio of mass by volume. Cement is not concrete, but can be used to make concrete by mixing it with sand, stone and water. The knowledge of the density of each of these material would allow a more accurate calculation of the proportions of a concrete mixture by volume instead of by mass. The density of cement is about 3120 kg/m^3 .
2. **Fineness:** the rate of chemical reaction largely depends upon the fineness of the cement. The finer the grading, the greater will be the rate of reaction.
3. **Consistency:** is determined by the amount of water (%) required to obtain the specified workability. The normal consistency of Portland cement is taken as 22-26%.
4. **Rate of setting:** is the phenomenon which changes a cement paste mortar to a solid but in weak stage. It is the chemical action which begins to take place when water is added to cement and results in the disappearance of the plastic nature of cement.

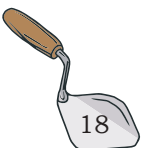

- 5. Rate of hardening:** is the process by which weak set mortar or concrete attains strength. It indicates the growth in strength of mortar or concrete. Hardening begins at the end of initial set and proceeds rapidly during the first few days. Later it continues to increase the strength at diminishing rate indefinitely. In humid and warm surroundings cement gains strength continuously but in dry condition the hardening process stops.
- 6. Waterproofing cement:** concretes prepared with this cement are more resistant to water penetration. It is used for construction of water retaining structures like tanks, reservoirs, swimming pools, dams and bridge piers, etc.

Lime

It has been considered as an important building material since ancient times. Many old forts, palaces, temples, bridges and monuments have been built using lime as cementing material. Lime is a binding material like cement. In the language of chemists, it is calcium oxide (CaO). It is still used in constructional work due to its peculiar properties.

Properties of lime

Lime is one of the basic building material used mainly as lime mortar in construction.

1. Lime provides good workability and has desired plasticity.
2. It prevents subsoil dampness due to certain level of waterproofing property.
3. Durability is high.
4. Porous texture of lime handles the moisture movement, without affecting the adjacent materials.
5. Has a higher acid resistance—due to its alkaline nature.

Uses of lime

Lime is used in various ways in the building industry.

1. It is used as a matrix for lime concrete used in building foundations and filling where early setting is not required.
2. It is used as binding material for preparation of

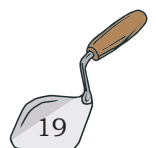

NOTES

- mortar for brick and stone masonry.
3. Lime is used as a cementing material in plaster for covering walls and pointing in joints.
 4. It is used for white-washing. Lime is also used to provide a base coat for distempers.
 5. Crushed limestone is used as aggregate for sand lime bricks.
 6. It is used in masonry works in the form of lime stone.
 7. It is used for water purification and sewage treatment work.

Practical Activity

1. Visit a market and collect the samples of different types of Cement and Lime.
2. Carry out the different types of field tests of cement.

Check Your Progress

A. Fill in the blanks

1. _____ is building material for preparation of mortar for brick and stone masonry.
2. Lime is a _____ material like cement.
3. Cement is used for _____ of mortars and cement concrete.
4. Waterproofing cement is more _____ to water penetration.
5. Crushed lime-stone is used as _____ .

B. Write short notes on

1. Properties of cement
2. Use of lime
3. Properties of lime
4. Waterproof cement
5. Composition of ordinary cement

C. Multiple choice questions

1. Main raw materials used for manufacturing of cement are _____ .
(a) lime (b) silica
(c) alumina (d) All of these
2. _____ is added to control the setting rate of cement
(a) Gypsum (b) Alumina
(c) Silica (d) Lime
3. The amount of water (%) required to obtain the specified workability is known as _____ .
(a) durability (b) consistency
(c) fineness (d) hardened concrete



SESSION 4: FERROUS AND NON-FERROUS METALS

Metals are one of the most significant engineering materials. Various types of metals are widely used in building construction works in one form or the other, for example, as reinforcing and structural materials. These are used in doors, windows, pipes and roofing's, etc. Metals are found in nature in the compound form of oxides, carbonates, phosphates, sulphides, etc. These compounds are known as ores. All metals used for engineering purposes are grouped into two categories—ferrous and non-ferrous.

All metals wherein iron is the main ingredient are called ferrous metals viz, cast iron, wrought iron and steel. The non-ferrous metals do not contain iron as their main constituent. Aluminium, copper, zinc, lead, tin, etc., are the commonly used non-ferrous metals in building construction.

Ferrous Metals

As described above, iron is the main constituent of the ferrous metals. Iron is achieved from iron ores. The iron ores are obtained by quarrying or mining.

Types of iron

There are three general classes of iron, i.e. cast iron, wrought iron and steel. Depending upon the nature and amount of carbon content, these differ from each other. The main properties and uses of different types of iron may be described as follows.

Cast Iron

It is obtained by re-melting and refining the pig iron in a special furnace called cupola furnace. The molten product is poured into moulds of required shapes and sizes to get cast iron. It is an alloy of carbon and iron with or without other elements.

Uses of cast iron

Cast iron is used for making pipes, manhole covers, struts in trusses, castings, rainwater pipes, gutters,



Fig.2.10: Ferrous and Non-ferrous Metals

NOTES

gratings, railings, cisterns, etc. Due to its high compressive strength, it is used for making columns, supports for heavy machinery, carriage wheels, bed plates, agricultural implements, etc.

Wrought iron

Wrought iron is the purest form of iron with low carbon content. It is made from white pig iron by re-melting and removing most of the carbon, manganese, silicone, phosphorus and sulphur in the puddling furnace.

Properties of wrought iron

1. Wrought iron is the purest form of iron and it is tough, ductile and malleable.
2. It has a fibrous structure and silky lustre.
3. It can be bent and twisted in either hot or cold stage.
4. It can be easily forged and welded.
5. It becomes so soft at 900°C temperature that its two pieces can be joined by hammering.
6. It rusts easily as compared to cast iron but it is not affected by saline water.
7. Wrought iron cannot be hardened and tempered but can be case hardened.
8. Its melting temperature is 1535°C.

Uses of wrought iron

Wrought iron is used for making roofing sheets, corrugated sheets, water and gas pipes, bolts and nuts, grills, gates, window guards, rods, boiler tubes, hand rails, railway couplings, fish plates, armature and electromagnets, etc.

Steel

Steel is an intermediate form between cast iron and wrought iron. It is an alloy of carbon and iron in specified proportion. The maximum carbon content in steel is limited to 2.1% of its weight.

Nowadays, steel is being commonly used in almost all fields of engineering. In the building construction works, steels are used as basic structural material in various forms.



Types of steel

Steel containing iron and carbon only, is called carbon steel or plain carbon steel, which is ordinary steel. Carbon steel is roughly divided into two categories, viz., soft steel, which contains less than 0.45% carbon and hard steel, which contains more than 0.5% carbon.

Mild Steel

It is a soft carbon steel and may contain 0.15 to 0.50% carbon. If the carbon content is less, than 0.15% then the steel is known as dead mild steel.

Uses of mild steel

Mild steel is used for all kinds of structural steel works. In construction work, it is mainly used in the form of rolled structural sections, such as IT and channel sections, angles plates, round and square bars 1 bolts, rivets and sheets, etc. MS round bars are extensively used as reinforcing material for reinforced cement concrete. Plain and corrugated mild steel sheets are used as roofing materials.

High Carbon Steel

Any steel with a carbon content of 0.55% or higher is known as high-carbon steel. High carbon steel has high tensile strength, is hard, wear-resistant and is moderately ductile. It is used to make cutting tools, because of its ability to keep a very sharp edge under duress. It is also used for making masonry nails, which can be pounded readily into rock.

Uses of high carbon steel

High carbon steel is used for manufacture of various workshop tools, such as drills, files and chisels, etc. It is also used to manufacture those various components of machines which are expected to expose to shocks and vibrations and need a hard, durable and tough material.

Cast steel is a high carbon steel which is formed by casting. It is the strongest and most uniform steel. It can neither be welded nor forged. Cast steel is less ductile and tougher as compared to ordinary steel. It is used for making high-grade surgical instruments.

NOTES

Steel Alloys

The generally used steel alloys in construction are given below.

Stainless steel

Stainless steel is corrosion resistant and has chromium, nickel, carbon and other elements in varying proportions in its composition. Chromium is the most effective ingredient to make steel corrosion-resistant. Stainless steel usually contains 18–20% chromium and 8–12% nickel. Steel containing above 16% chromium is called stainless steel. Stainless steel of various brands are available in the market.

Uses of steel

Generally, steels are used for the following purposes.

1. As basic reinforcing material in construction works.
2. As structural material in trusses, beams, stanchions and light frames in the form of various sections.
3. As components for doors, windows and grills, etc.
4. For manufacture of pipes, tubes, tanks and ducts etc.
5. For sanitary and sewer fittings.
6. Form expanded metal and metal lath.

Advantages of steel as reinforcing material

Steel is commonly used as reinforcing material due to its following qualities.

1. Steel possesses high tensile strength and elasticity.
2. It develops good bond with concrete.
3. It is cheaply and easily available in bulk.
4. Its thermal coefficient is nearly equal to the thermal coefficient of concrete.
5. Its use is economical.

Non-ferrous Metals

Metals, which do not contain iron as their main constituent, are called non-ferrous metals.

Aluminium

It is extracted from bauxite ore by various processes. It is a bluish silvery white lustrous metal. Pure aluminium



is soft, highly ductile and malleable, hence it is alloyed (mixed) with some other metals for improvement of its qualities. It is a light, durable and easily workable metal. Aluminium is a good conductor of heat and electricity and highly resistant to corrosion. It can be welded and riveted.

However, its soldering is not possible. Sheets, plates, foils, bars, rods, wires, casted, forged or rolled structural parts and cooking utensils are the commercial forms of aluminium. Aluminium is used for making frames of doors and windows, corrugated sheets for roofing, piping, railings, posts, and panels in building construction. It is used in powdered form in paints.

Being a tough and light metal, it is very commonly used in automobile, wireless and airplane industries. It is used for making electric wires and cables, etc. Due to its good conductivity.

Practical Activity

1. Visit a market and collect the samples of different types of ferrous and non-ferrous metals.

Check Your Progress

A. Fill in the blanks

1. Iron is achieved from iron _____. The iron ores are _____ by quarrying or mining.
2. Wrought iron is the _____ form of iron with low carbon content.
3. The non-ferrous metals do not _____ iron as their main constituent.
4. Three general classes of iron are cast iron, _____ and steel.
5. High carbon steel contains 0.70 to _____ % carbon.

B. Write short notes on

1. Ferrous material
2. Non-ferrous material
3. Uses of steel
4. Wrought iron

C. Multiple choice questions

1. Which is the purest form of iron?

(a) Wrought iron	(b) Cast iron
(c) Steel	(d) None of these



2. Which among the following does not belong to the nature of pure aluminium?

(a) Soft	(b) Highly ductile
(c) Malleable	(d) Brittle
3. Stainless steel usually contains _____ chromium and _____ nickel.
 - (a) 18–20% and 8–12%
 - (b) 15–18% and 8.5–11.5%
 - (c) 18.5–20.5% and 7–12%
 - (d) 18–20% and 9–12%
4. Melting temperature of wrought iron is _____.

(a) 1535°C	(b) 1538°C
(c) 1537°C	(d) 1532°C

SESSION 5: MORTAR AND CONCRETE

Mortar and Concrete

Mortars and concretes are the mixtures of binding material, aggregate and water. These are extensively used in construction industry. Mortars and concretes shall be discussed separately in this chapter.

Mortar



Fig.2.11:Mortar

Mortar is a workable paste used to bind building block, such as stones, bricks, and concrete masonry units together, fill and seal the irregular gaps between them, and sometimes add decorative colours or patterns in masonry walls. Mortar may be defined as a plastic mixture (paste like substance) of a binding material, fine aggregate and water in appropriate proportions. Generally, cement, lime or soil, (clay) is used as binding material and sand or *surkhi* as fine aggregate for preparation of mortars.

Functions of mortars

Mortars are used for

1. uniting bricks or stones in masonry works. Concrete blocks are also bound together using mortars.
2. providing an even bed between different layers of masonry, this results the even distribution of load on the lower layers.
3. forming matrix to hold the pieces of aggregates together. This leads to formation of solid mass of concrete.

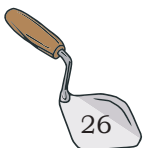

4. These are used as covering materials to wall surfaces and joints in the form of plaster or pointing. These coverings protect the masonry surfaces from weather and provide hard, durable and decorative surfaces.

Ingredients of mortars

The main ingredients of mortars include binding material, fine aggregates and water.

Binding material

Cement, lime and clay are commonly used as binding material in preparation of mortars. The soil for making mud mortar should have suitable plasticity. It should be free from vegetative roots, stones and gravels (particles size greater than 2 mm), *kankar*, coarse sand and harmful efflorescent salts.

Cement and lime are the best binding material used in the preparation of mortar.

Fine aggregates

Sand and *surkhi* are commonly used as the fine aggregate for preparation of mortars. Important qualities of commonly used fine aggregates are summarised here.

1. Sand: is the most commonly used fine aggregate for mortar preparation. Clean, coarse, hard and durable, sand should be used for mortar preparation.

Functions of sand in mortar

Sand, used in mortar preparation performs the following functions —

- a) an adulterant to increase the volume of mortar to make it economical.
- b) prevents excessive shrinkage of mortar and consequently cracking of mortar on setting is avoided.
- c) helps in setting of pure lime mortar by allowing the penetration of air, containing carbon-dioxide through voids, needed for setting of lime.
- d) helps in improving the strength of mortar or concrete.



NOTES

e) it, being an inert material, makes the structure more resistant against atmospheric agencies.

2. Surkhi: is used as a substitute of sand and obtained by grinding well burnt (but not over or under burnt broken bricks). It should not contain any harmful impurities, such as salts, iron pyrites, coal, shale and other deleterious materials. The maximum quantities of clay, silt, dust and organic impurities in surkhi should not exceed 5% by weight.

3. Cinder: is used as fine aggregate for mortar preparation. Cinder obtained from the furnace of steam boilers should only be used.

4. Fly ash: is obtained from the combustion of pulverised coal in boilers. It is used for partial replacement of cement in mortar or concrete. Nowadays 10-20% fly ash is added as replacement of cement in cement bags. This helps in environmental preservation as well as cost reduction.

5. Water: to be used for mortar preparation should be clean and reasonably free from injurious quantities of deleterious materials, such as oils, acids, alkalis, salts and vegetative growth. Generally, drinking water should be used for mortar preparation.

Proportioning of mortars ingredients

The strength and durability of masonry considerably depends on the mortar used.

The composition of mortars is designated by two or three numbers, for example, the composition of ordinary Portland cement mortar is designated as 1:4. This means that in a given mortar, four unit volume of sand are mixed with one unit volume of cement. The composition of compound mortar is designated by three numbers; a cement lime mortar of 1:0.5:5 composition contains one part of cement, 0.5 part of lime and five parts of fine aggregate (sand) on volume basis. These compositions are prepared on the basis of laboratory tests conducted for various proportions of mortars.



Classification of mortars as per use

Mortars may be classified as per use in the following ways:

Mud mortar

This is also called Gara and is the cheapest mortar. It is prepared from a mixture of soil (clay) and water in appropriate proportions. The mixture is mixed under feet to get required consistency. Spade is used for turning and mixing of mortar. It is mostly used in villages in *kutchha* and *pucca* masonry works. However, plastering or pointing of masonry is necessary to maintain durability and to avoid erosion due to rains. It can also be used for plastering of *kutchha* huts and for erection of mud walls. Straw should be mixed at a rate of 1–18 kg of dry soil while using it for erection of mud walls.

Cement mortar

This is a stronger mortar and preferred for construction of structures subjected to heavier loads, for example load bearing walls, pillars and columns, etc. It consists of the mixture of cement, sand and water in appropriate proportions. Generally, the proportion of cement to sand varies from 1:2 to 1:6 or more. It provides impervious surfaces and advantageously used for external walls, exposed situations and underground structures.

For preparation of mortar, cement is measured in bags. Each bag contains 50 kg cement having 32 litre volume. Sand is also mixed on the basis of dry volume but appropriate allowances should be provided considering bulk age of sand.

A box of 25×35×40cm size may be prepared and conveniently used for measurement of sand. Cement and sand is mixed in required proportions in dry state on an impervious plate form. Some of the commonly used proportions of cement and sand mortar for specific purposes are presented in table.

Table 2.1: Commonly used proportions of cement-sand mortar

S.no.	Work	Ratio
1.	Masonry work	1:6 to 1:8
2.	Foundation concrete	1:3 to 1:4
3.	R.C.C. works	1:3
4.	Arch works	1:3

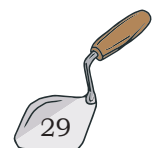

S.no.	Work	Ratio
5.	Plastering work	1:3 to 1:6
6.	Pointing work	1:1 to 1:3
7.	Damp-proof course	1:2
8.	Partition walls	1:3
9.	Lintels, pillars, slabs and stairs, etc.	1:2

Lime mortar



Fig.2.12: Lime Mortar

It consists of mixture of lime, sand and water in suitable proportions. Sand is added to control shrinkage. Slaked fat lime is used in mortar to be used in plastering and hydraulic lime is used for preparation of mortar to be used in masonry construction works. Lime mortar may be composed of lime-sand, or lime-surkhi, or lime-sand-surkhi or lime-cinder (black mortar).

Properties of good mortar

Effective mortars should have —

1. smooth mobility (mobility of mortar is its ability to spread easily over the surface in the form of thin layer and fill all irregularities).
2. water holding capacity and should not bleed (water holding capacity is the property of mix to hold water when placed on a surface). In case of bleeding, water flows away and fine aggregate (sand) is separated.
3. enough strength and good adhesion to hold bricks and stones, etc.
4. the ability to set and harden quickly and should provide durable surfaces.

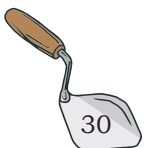

Fig.2.13:Concrete

Concrete

Concrete is a mixture of a cementing material, fine aggregate, coarse aggregate and water along with or without a suitable admixture.

Generally, sand is used as a fine aggregate and crushed stone or crushed boulders or



gravels are used as coarse aggregates. Admixtures are the ingredients or the substances which are added in concrete to improve its various properties, such as workability, setting time, etc. Commonly used admixtures include alum, common salt, lime, aluminium sulphate, bitumen and calcium chloride, etc.

When cement is used as cementing material in concrete mix then it is known as plain cement concrete. If steel is used to provide reinforcement in cement concrete, it is called Reinforced Cement Concrete (RCC).

If lime is used as cementing material then it is called lime concrete. Reinforcement cannot be provided in lime concrete because it eats away steel in due course of time. Sometimes, part of sand is replaced by *surkhi* and thus achieved concrete is called surkhi concrete. Freshly prepared concrete (that has not yet set) is called wet or green concrete. After thorough setting and hardening of concrete, it is called set concrete or hardened concrete.

Nowadays, concrete is extensively being used for all types of construction works in various forms, for example, plain or reinforced or precast concrete, etc. Concrete is mainly used in foundations, columns, beams, slabs, stair cases, lintels, door and window frames and storage tanks, etc., in building construction works.

Ingredients of concrete

Cement

This ingredient binds the aggregates together and provides strength, durability and water tightness to concrete. It is an active constituent of concrete.

Aggregates

The aggregates act as fillers in concrete. These are used in concrete to provide economy in the cost of concrete as well strength. Aggregates occupy about 80 to 85% of concrete volume and form its rigid skeleton, which prevents shrinkage and contraction.

Sand is used as a fine aggregate in preparation of concrete. Stone, gravel and brick ballasts are commonly used as coarse aggregate for preparation of concrete.

NOTES

Aggregates should be staked separately according to their nominal sizes.

Advantages of concrete

1. The ingredients of concrete are easily available for concrete preparation.
2. Handling of concrete is easier and it can be moulded in any desired shape.
3. Concrete can easily be transported from the place of mixing to the place of casting.
4. When concrete is reinforced then all types of structures are made possible, for example, from ordinary lintel to massive flyover.

Disadvantages of concrete

1. It has low tensile strength and requires reinforcement to avoid cracks.
2. Soluble salts in concrete cause efflorescence after reacting with moisture.
3. Sustained loadings develop creep in concrete structures.
4. Construction joints are provided to avoid cracks because of drying shrinkage and moisture expansion.

Types of concretes

Cement concrete

It is mixture of cement, sand, gravel or pebbles and water in appropriate proportions. Some materials like alum, common salt or calcium chloride, etc., may also be added in cement concretes to improve its properties.

Cement concrete is an important structural material and extensively used in variety of construction. It is strong in compression and weak in tension. Generally, coarse aggregates having upto 63 mm diameter are used for mass concrete; whereas aggregates having upto 25mm diameter are used for preparation of concrete for slab, beam and columns, etc. The concrete mixes having 1:2:4, 1:3:6 and 1:4:8 proportions are generally used and known as strong, medium and lean mix, respectively.



Lime concrete

It is the mixture of slaked lime, fine aggregate, coarse aggregate and water in suitable proportions. Hydraulic lime is always used in preparation of this concrete.

Lime concrete is extensively used as levelling coarse for foundations of the buildings and as base concrete under floors. It is also used to provide roof finishes and used for filling of haunches over masonry arch work. Lime concrete is cheaper than cement concrete.

Surkhi concrete

This is prepared by mixing slaked lime, sand, *surkhi*, coarse aggregate and water in appropriate proportions. Surkhi concrete having 1:1:5:0.5: 4 (lime, sand, *surkhi* and coarse aggregate) proportion is commonly used in various construction works.

Composite mortar concrete

This is a mixture of cement, non-hydraulic lime, sand, coarse aggregate and water in appropriate proportions. Different proportions of composite mortar concrete are used for different types of works like basement concrete floor, etc.

Reinforced Cement Concrete (RCC)

We know that plain cement concrete is strong in compression but weak in tension and shear. The cement concrete can be made stronger in tension also by embedding steel bars in it.

The concrete, in which reinforcing metals have been embedded to enable it to take up tension safely, is called reinforced cement concrete. Generally, steel is used as reinforcing material because it possesses high tensile strength and elasticity. Steel develops good bond with concrete and it is cheaply and easily available in bulk. Its thermal coefficient of expansion is also nearly equal to that of concrete.



Fig.2.14: Reinforced Cement Concrete

Advantages of R.C.C.

The R.C.C. has following advantages over plain concrete.

1. R.C.C. structures are strong enough. The combination of concrete and steel provides much rigidity to structures.

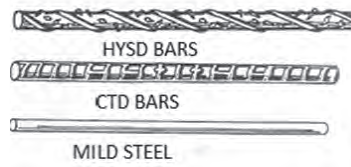

Fig.2.15 Types of Reinforcement

2. The maintenance cost of R.C.C. structures is less because these are not affected by termites, etc.
3. The combination of concrete and steel is economical because compressive forces are borne by concrete and tensile forces by steel.
4. R.C.C. structures are almost impervious.
5. R.C.C. structures are durable and can withstand fire.
6. R.C.C. structures can be constructed of any desired shape.

Uses of R.C.C.

Reinforced cement concrete is extensively used in all sorts of construction works of buildings, bridges, arches, tanks and massive dams, etc.

Practical Activity

1. Carry out the volumetric measurement of sand and coarse aggregates.
2. Prepare cement mortar by hand mixing
3. Prepare cement concrete by hand mixing
4. Visit a construction site and observe the method of mixing of cement concrete by machine mixing.

Check Your Progress

A. Fill in the blanks

1. Mortar is the basic _____ used in stone and brick masonry and in other structural units.
2. Cement, lime and clay are commonly used _____ materials in preparation of mortars.
3. Sand and *surkhi* are commonly used as the _____ aggregate for preparation of mortars.
4. *Surkhi* is used as substitute of _____ and obtained by grinding well burnt broken bricks.
5. Mud mortar is also called _____ and is cheapest mortar.
6. Cement concrete is _____ of cement, sand, gravel or pebbles and water in appropriate proportions.
7. Reinforced cement concrete is extensively _____ in all sorts of _____ works of buildings, bridges, arches, tanks, massive dams, etc.

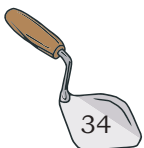

B. Write short notes on

1. Concrete
2. Mortar
3. Reinforced Cement Concrete(RCC)
4. Lime Concrete
5. Aggregates

C. Multiple choice questions

1. Aggregates occupy about _____ of concrete volume.

(a) 80 to 85 %	(b) 80 to 90 %
(c) 70 to 85 %	(d) 82 to 85 %
2. Concrete Ratio 1: 2: 4 is designated as _____.

(a) M-10	(b) M-20
(c) M-15	(d) M-7.5
3. Cementious material produced in thermal power plant which also a waste is known as _____.

(a) cinder	(b) <i>surkhi</i>
(c) cement	(d) fly ash
4. Which of the following is the best binding material?

(a) Cement	(b) Fly ash
(c) Lime	(d) <i>Surkhi</i>

SESSION 6: BUILDING FINISHING MATERIAL**Building Finishing Material**

The material which are used to provide the building finishes or the final look are called building finishing materials. Common building finishes include plastering, pointing, white-washing, colour washing, wall papering, painting, varnishing, polishing, etc. Building finishes are done with the following objectives.

1. To provide decorative appearance on material surfaces and building as a whole.
2. To provide a protective coating to surfaces against various weathering effects, such as rust and heat, etc. The materials used in building construction are protected and preserved by this coating.
3. To maintain hygienic conditions in the buildings.

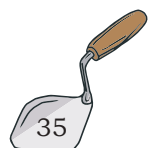

NOTES

Various types of building finishes and materials required are given here.

Plastering

A plaster is a thin coat of mortar of different composition, which covers the face and hides the joints of walls and ceilings of buildings. The process of covering various surfaces of structures with a plastic material, such as cement mortar, lime mortar, composite mortar or mud mortar is called plastering. It provides an even, smooth, regular, clean and durable surface. Plastering conceals the slight flaws of workmanship also. It further provides a protective coating against atmospheric effects and base for receiving other decorative finishes; for example, white washing, colour washing, painting, etc. When plaster is applied on the external exposed surfaces of walls, then it is called *rendering*.

Pointing

The art of finishing the mortar joints in the exposed brick or stone masonry using suitable mortar is called pointing. It protects the joints from weather effects and improves the appearance of the buildings. In plastering, whole surface is covered with mortar, whereas, in pointing, only joints are filled with mortar.

Pointing is usually carried out using cement or lime mortar but sometimes composite mortars are also used. The cement mortar for pointing is prepared by mixing cement and sand in ratio of 1:2 or 1:3. Similarly, lime mortar is prepared by mixing equal parts of fat lime and fine sand and grinding the resultant mixture thoroughly. Composite mortars having cement:lime: sand proportion in 1:3:10 or 1:4:16 are successfully used for pointing work. The mortars must be well pressed into joints at the time of pointing.

White washing

It is the process of application of wash covering to the plastered surfaces. The white wash is prepared using pure fat lime or shell lime. Since shell lime is whiter, slakes more perfectly and makes smoother paste as compared to lime stone, so it is preferred for preparation

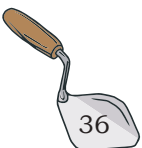

of white wash. Lime is brought to site in unslaked condition and it is slaked in a tub with sufficient quantity of water. It is allowed to remain in the tub for 24 hours and then stirred to attain the consistency of thin cream. Approximately 5 litre water should be added into 1kg of lime for making cream. Before application of white wash, the surface should be cleaned properly. White wash may be applied using *moonj* brush. A vertical stroke followed by a horizontal stroke constitutes one coat of white wash.

Colour washing

Colour washing is similar to white washing. Colour wash is prepared by adding appropriate quantities of necessary colouring pigments into the strained white wash. This preparation is mixed well. Mineral colours, which do not get affected by lime should be added with white wash.

While preparing the colour wash, it should be kept in mind that the prepared quantity of colour wash should be used in the same day that it is prepared. For new surfaces priming coat of white wash should be provided followed by one or two coats of colour wash as per the need. Also, for replacing one colour with another, a coat of white wash should be applied followed by the desired colour wash. The method of application of colour wash is same as of white wash.

Distemping

The process of application of distempers on the various surfaces is called distemping. Distempers form a cheap, durable and easily applied decoration for internal use on plastered surface, cement concrete and various wall board surfaces. Distempers are known as water paints also.

Wall papering

The process of pasting of papers on the walls and ceilings inside the rooms is called wall papering. It is performed to provide beautiful appearance inside the rooms and buildings as whole. The wall papers are made exclusively from papers or combined with other materials. Usually, wall papers are available in different colours.

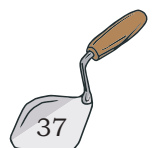

Method of Wall Papering

The surfaces, to which wall papers are to be pasted, are dried, levelled and freed from dirt, white or colour wash or any other solution. All the cracks, slits and pits are filled with lime gypsum putty solution. This is followed by pasting of wrapping paper or newspaper on the prepared surfaces. Then, wallpapers are pasted on it. Pastes prepared from wheat flour, starch, joiner's glue, synthetic resins or gluing mastics are used to paste papers on the walls. The wallpapers are available in rolls or sheets in the market. Papering is not suitable in damp climate and places infested with white ants.

Paints



Fig.2.16: Paint boxes

Paints are the ready mixture of material which are applied, in the liquid state, to all surfaces as a final finish. Generally, these are applied on walls, ceilings, wood and metal works. The process of application of paint in the form of coating is called painting. The purpose of painting is to prevent corrosion of metals and to protect wood from decaying, protect various surfaces from weathering effects (heat, moisture and gases) of atmosphere and to provide decorative finish and attractive appearance to all the surfaces.

Paints are classified as oil paints, water paints, cement paints and bituminous paints. There are, some special purpose paints also, which are used for painting, such as, heat resistant paints, water proofing paints, chlorinated rubber paints for protection against acid fumes and luminous paints for visibility of painted surface in dark, etc.

Types of paints and their uses

Aluminium paints

These paints consist of aluminium powder suspended in spirit or oil varnish. After evaporation of suspension liquid, i.e., spirit or oil, a thin metallic coating of Aluminium particles are formed on the painted surface. It is visible in darkness due to its silvery shining texture.

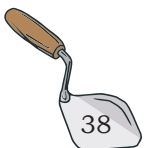

It has very good covering capacity and provides nice protection to iron and steel against corrosion. It is heat, electric and weather resistant. It is commonly used for painting hot water pipes, oil storage tanks, gas tanks, metal roofs, silos, electric and telegraph poles, marine piers, radiators and other machineries. It is used for painting wood work also.

Anticorrosive paints

As the name indicates, these paints are anticorrosive in nature. These paints consist of oil, a strong drier and a colouring pigment mixed with fine sand. These are durable and provide black appearance to painted surface.

Asbestos paint

The fibrous asbestos is the main ingredient of this paint. This paint has fire retarding quality. It can also withstand the effects of water, steam and acidic gases. It is commonly used for painting of public buildings. It is also used to check the leakages from metal roofs. This paint is also used for gutters, spouts and flashings, etc. to protect them from rusting.

Bituminous and tar paints

These paints are prepared by dissolving bitumen or tar in naphtha or petroleum or white spirit. Generally, these paints are black in colour but their colour may be modified by addition of colouring pigments, like, red oxide, etc. These paints have high covering capacity.

Bituminous paints are especially used for painting of iron and steel structures under water. These paints are also used for painting of plastered surfaces and exterior brickworks.

Oil paints

These paints are cheap, durable, weather resistant and present good appearance. These paints are generally used for all type of surfaces, for example, wood work, walls, ceilings and metal works. These are applied in three different coats, i.e. priming coat, under-coat and finishing coats, etc.

NOTES

Cement paint

It is prepared by mixing cement (65–75%) Portland, white or coloured cement) into boiled Linseed oil. Cement paint has good strength, hardness, density, durability and possesses better waterproofing quality. It provides nice decorative appearance. Cement paint is used for painting of stone masonry, plastered brick masonry and corrugated iron sheets.

Emulsion paints

These paints are durable, alkali resistant, easily workable and have quick drying quality. Emulsion paint has enough toughness and retains its colour for long time. These are used for painting of surfaces containing free alkali like stucco and brick masonry.

Enamel paints

The main constituents of enamel paints are metallic oxide (zinc oxide or lead oxide), oil, petroleum spirit and resinous matter. These paints dry slowly and leave a hard, tough, smooth and durable film on the painted surface. Enamel painted surfaces are washable and resistant to acids, alkalies, gases and steam. These paints have flow properties and leave no brush mark on the painted surface. These paints are equally good for painting of external and internal works and has glossy appearance. Enamel made from synthetic resins are known as synthetic enamels. These dry quickly and are more durable.

Plastic paint

Various types of plastics are used as base of these paints. These paints are available in market in different shades and trade names. When water is used as thinner then, these are called as plastic emulsion paints. Plastic paints dry quickly and provide decorative appearance. These have good adhesion and high covering capacity. Plastic paints are used at the places where attractive appearance is desired, for example, cinema halls, offices, auditoriums, showrooms, etc.

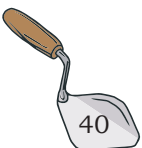

Fire-proof paint

Coatings of sodium tungstate and asbestos paints are used to retard the fire action. These are known as fireproof paints. Either of these solutions is used to provide fire resistant quality to timber works.

Colour scheme for walls

Red, yellow and blue are the three primary colours and all other colours are mixtures of these three. Red, orange and yellow are called warm colours; whereas, violet, blue and green are called cool colours. White, pure greys and black are called neutral colours. Excess of red or orange is upsetting, most uncomfortable to live with in hot climate.

The selection of right colour is very important before its application. The right colour can make a room look bigger. White colour is popular in contemporary homes. It gives a crisp finish to a scheme and looks light and fresh. Blue is usually a difficult colour. In a blue room, wall reflects strongly upon each other. Pink becomes paler with time. Grey is essentially a cool and excellent background colour.

Varnish

Varnish is a solution of resinous substances in either oils, turpentine or alcohols. Resinous substances, such as, amber, copal and shellac are used in preparation of varnishes. After drying, varnish leaves a hard, transparent and a glossy film of resins on the varnished surfaces. The process of application of varnish on various surfaces is known as varnishing.

Varnish is applied to the painted surface to increase its brilliance and to protect it from the atmospheric actions. Thus, it increases the durability of the paint film. Varnish is also applied on the unpainted wooden surfaces to brighten the ornamental appearance of the grains of wooden surfaces, such as doors, windows, floors, roof trusses, etc.

Ingredients of varnish

Resins, solvents and driers are the main ingredients of the varnishes.



Fig.2.17: Varnish

Types of varnish

Oil varnish

These varnishes are prepared by dissolving hard resins such as amber and copal, etc., in linseed oil. Small quantity of turpentine is also added to achieve its proper workability. These varnishes are most durable and hardest as compared to all other varnishes. These provide higher gloss and smoother finish to the varnished surface. Oil varnishes are used for varnishing of interior and exposed surfaces which require polishing and frequent cleaning. Flat varnish is also an oil varnish having high proportion of resins.

Turpentine varnish

Turpentine is used as solvent in preparation of these varnishes. Various soft resins, such as mastic, gum *dammar* and common resins, etc., are dissolved in turpentine oil. These varnishes are cheaper, lighter in colour, more flexible and dry quickly than the oil varnishes.

Polish

Polishes are thin varnishes, which are lightly rubbed on the surfaces just like the brush polish.

Furniture polish

As the name indicates, it is generally used for polishing furniture. It can be prepared at the domestic level by mixing following ingredients in the suggested proportions.

Wax polish

Wax polish is prepared by mixing two parts of beeswax with two parts of boiled linseed oil over the slow fire. After some time the wax gets dissolved in the oil. Now one part of turpentine is added in this slightly warm mixture. Thus prepared, the polish is ready for use. It is rubbed into the pores of wood with cotton pad. For a good finish, normally three applications are required. Wax polish is mostly used for polishing cement concrete floors.

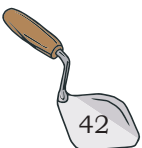

Lacquer

Lacquer is like a very thin varnish. It consists of shellac, methylated spirit and colouring pigments. Depending upon the desired use, these may be mixed in different proportions. On drying, these provide a tough and durable finish. Lacquers are used for furnitures, brass surfaces, floor and linoleum, etc.

Stains

Stains are liquid preparations. Aniline is mostly used as base and water, oil and alcohol, etc., as vehicle in preparation of stains. These are named after the vehicle used in their preparation. Water stains are cheapest but provide rough coating on the wooden surface. Spirit stains dry very quickly hence require an expert painter for their application. Oil stains are most suitable for their use on hard wood works.

Wall tiling

The process of lining or finishing the walls with special tiles (either for height varying from 60–120 cm above the floor level or up to the ceiling) is known as wall tiling. Generally, wall tiling is used in passages, kitchens, bathrooms, fire places, staircase walls and boiler rooms, etc. Wall tiling is provided to give decorative effect over the surfaces. The wall tiles are either of terracotta, faience, China clay or marble. They are available in variety of colours, sizes and thicknesses.

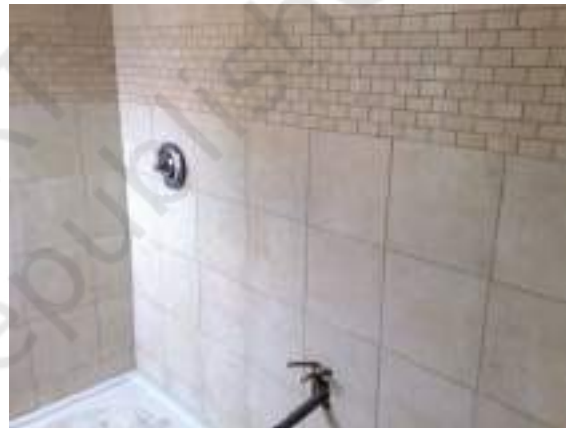

Fig.2.18: Wall Tiling

Whitening

It is the process of whitening the walls and ceilings by a mixture of ground chalk, glue and water.

Coal tarring

The process of application of coatings of coal tar to wood work or iron work is called coal tarring. It is done to preserve the surfaces. The tarred surfaces can further be treated by varnishing or painting.

NOTES

Wood oiling

It is used as a substitute for painting on woodwork. It is done to increase the durability and to improve the appearance of surfaces. Generally, linseed oil, turpentine or sweet oil is used for oiling.

Practical Activity

1. Visit a market and look for building finishing materials.
2. Prepare the following paints:
(i) White washing, (ii) Colour washing, (iii) Distemper, (iv) Oil Paint, (v) Furniture polish

Check Your Progress

A. Fill in the blanks

1. A plaster is a thin coat of _____ of different composition.
2. Process of pasting of papers on the walls and ceilings inside the rooms is called _____.
3. The art of finishing the _____ joints in exposed brick or stone masonry using suitable mortar is called pointing.
4. The process of lining or finishing the _____ with special tiles is known as wall tiling.
5. The process of application of coatings of coal tar to wood work or iron work is called _____.

B. Write short notes on

1. Building finishing materials
2. Plastering
3. Pointing
4. Wall tiling
5. Polishing
6. Plastic paint
7. Oil paints

C. Multiple choice questions

1. Lacquers is used for _____.
(a) furnitures (b) wall painting
(c) ceiling painting (d) None of these
2. The art of finishing the mortar joints in exposed brick or stone masonry using suitable mortar is called _____.
(a) plastering (b) white washing
(c) colour washing (d) pointing

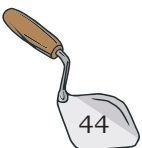

3. Coatings of _____ and asbestos paints are used to retard the fire action.

(a) Sodium carbonate	(b) Sodium hexane
(c) Sodium tungstate	(d) Titanium oxide
4. Resinous substances used in preparation of varnishes are _____.

(a) amber	(b) copal
(c) shellac	(d) All of these

SESSION 7: MISCELLANEOUS MATERIALS

Many miscellaneous materials are designed and developed as per requirement. Some such materials popularly used are described here.

Plastics

Nowadays, plastic is being used widely in the construction industry due to its several advantages over conventional construction materials. Plastic products are light weight and provide sufficient strength and corrosion resistant property. Plastics provide better hygiene and exhibit pleasing look. Plastic is a synthetic material made from polyethylene, nylon, polyvinyl chloride, etc.

Uses of plastics

In the building industry, plastics are used for different purposes such as wall tiling, roofing, heat insulation, wall panels, doors, etc. These are used as floor coverings in domestic, administrative and industrial buildings. Different types of plastics are used in plumbing and air conditioning units in various forms, for example, pipes, couplings, elbows, union tees, shower stalls and tubes and parts and joints of sewer system and taps.

Types of plastics

PVC (Polyvinyl chloride)

It is a kind of thermoplastic achieved from vinyl chloride and acetates. It is light weight and can be easily cut. PVC can withstand wear and tear, acids and alkalies. It is not affected by moisture. PVC is used for manufacture of drainage pipes, electric wire insulation, flooring

finishes and emulsion paints, etc. PVC linoleums are used for covering floors in domestic, civil and industrial buildings. One ply linoleum is usually 1.5-2.5 mm thick; whereas felt or porous base linoleums have 4-6 mm thickness.

Polyethylene

Alkathene and Polythene are the trade names of this transparent thermoplastic. Polyethylene is used for making pipes, for cold water services, cistern ball floats water proofing material, for terraced roofs, reservoirs and canals, etc.

Perspex

It is a proprietary thermoplastic resin which provides light and tough sheets. These sheets do not break easily. Perspex sheets are exceptionally transparent and can be cut, drilled, sawn and planed easily. These are available in attractive colours.



Fig. 2.19: Decorative veneer plastic used on kitchen cabinets

Wood laminated plastics

Wood laminated plastics are used as finishing material for walls, partitions and ceiling boards in public buildings.

Decorative laminated plastic veneer

These versatile sheets are marketed under trade names of Formica, Sunmica, Sunglass and Decolum, etc. These are used where elegance, durability and hygiene are the main considerations. Table tops, wall panels, kitchen and bathroom counters, interior bodies of trains, bushes, aircrafts and ships are made from these plastics.



Fig.2.20: Glass

Glass

Glass is extensively used in building construction for various purposes, for example, for glazing doors and windows, insulation and for decoration, etc.

Properties of glass

Glass is brittle, transparent or translucent and it is available in beautiful colours. It has amorphous

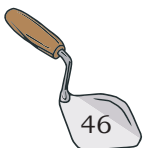

structure. Glass absorbs and reflects light. It can be casted into desired shapes and can be welded by fusion. It is not affected by chemicals.

Fixing of glass panes

Glass panes are secured in place by means of putty or wooden moulds. Putty is made by mixing one part of white lead with three parts of finely powdered chalk. Boiled linseed oil is added to mixture to form a stiff paste. This paste is well kneaded and left well for twelve hours covered with a wet cloth. Sometimes little varnish is added to the paste. Thus prepared putty is known as Glazier's putty. About 185 grams putty is required for fixing and securing the glass panes, per meter of glass perimeter.

Sound Insulating Materials

It is well established that high noise conditions result in uncomfortable living, cause fatigue, inefficiency and mental strain. Prolonged exposure to noisy conditions may cause temporary deafness or nervous breakdowns. Hence, sound proofing and insulation is essential requirement of buildings. Sound proofing is absolutely essential in the cases of radio broadcasting stations, television stations, sound recording studios and film studios, etc.; whereas, sound insulation is important for office buildings, hospitals, hotels and educational institutions etc.

Acoustics and sound insulation are the functional requirement of most of buildings. Acoustic is the science of sound, which assures the optimum conditions for producing and listening to speech and music, etc. The function of sound insulation is the prevention of transmission of sound by any means, whereas sound absorption is the prevention of reflection of sound waves. Compressed straw slabs, cork slabs, slag wool, sponge rubber, wood shavings, felt, bitumen, asbestos, rock wool, acoustic plaster and breeze bricks are widely used as sound insulating materials. A layer of 12 to 25 mm thickness of these materials is usually sufficient for sound insulation.

NOTES

Damp-proofing

Dampness in the buildings occurs due to faulty design of structures, poor workmanship and faulty construction and use of poor materials of construction. Dampness results in peeling off of plaster and exposing of steel reinforcement. Hence damp proofing in buildings should essentially be done.

Source of dampness

The main sources of dampness includes orientation of the building, penetration of rain water from the exposed tops of walls, rise of ground water table, poor drainage, condensation due to atmospheric moisture and poor workman ship.

Effects of dampness

Damp buildings create unhealthy living and working conditions for occupants. Dampness promotes the growth of termites. It may promote breeding of pathogens of tuberculosis, neuralgia and chronic rheumatism. Dampness causes softening, crumbling of plaster, efflorescence on building surfaces, corrosion of metals, bleaching and flaking of paints.

Prevention of dampness

Dampness can be prevented by the following techniques and methods.

1. Use of damp-proofing course
2. Damp-proof surface treatments
3. Integral damp proofing treatments
4. Guniting or shot concrete or shotcrete
5. Cementation
6. Cavity walls

In the case of damp-proofing course (DPC), layers or membranes of water repellent materials are used. Water-proofing or damp-proofing surface treatments include filling up the pores of the materials exposed to moisture by providing a thin film of water repellent material over the surface. Some surface treatments like pointing, plastering, painting and distempering are provided to check the dampness. Most commonly used treatment to protect walls against dampness includes

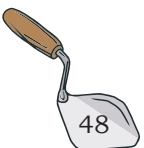

application of lime-cement-plaster in 1: 1: 6 proportion. A thin film of water proofing materials may be applied on the surface of concrete.

The waterproofing agents used in surface treatments include potassium or sodium silicates, aluminium or zinc sulphates, barium hydroxide and magnesium sulphate in alternate applications. In the case of integral damp-proofing treatment certain compounds are added to concrete or mortar during mixing. These compounds include chalk, talc, fuller's earth, aluminium sulphate, calcium chloride, soap, petroleum oils and fatty acid compounds. Different damp-proofing synthetic compounds are also available in the market with various trade names, such as, Pudlo, Sika, Novoid, Ironit, Dampro, Permo and Rainex, etc. A 12-mm cement plaster in 1:2 proportion with some waterproofing compound may be laid above the plinth masonry with one or two thick coats of hot coal tar to check the dampness. Under shortcrete method of damp-proofing, a rich mixture of cement and sand in 1: 3 proportions is applied on the surfaces to restrict the dampness.

In the cementation method, cement grout; i.e., mixture of cement-sand and water is forced into the cracks under pressure to stop the dampness. Dampness can be prevented by use of cavity walls or hollow walls. In this method a cavity space of 50 mm to 80 mm is left between the walls.

Damp-proofing material

Following are some of the commonly used damp-proofing material:

1. Bitumen or Hot Asphalt: is a product of petroleum industry. It is non-crystalline solid or viscous material having adhesive properties. Bitumen is black or brown colour.

2. M. Seal: is a patented compound available in the market to stop the leakages. It is composed of two compounds. These compounds are mixed thoroughly in equal proportions to form putty. This putty is filled or pasted into the leakage cracks and spots to stop the leakages.



Fig.2.21: Damp-proofing Materials

NOTES

Characteristics of an ideal damp-proofing material

- An ideal damp-proofing material should be impervious and durable.
- It should be able to resist dead and super-imposed loads.
- It should provide lesser number of joints when laid over larger areas.
- A good damp-proofing material should not develop cracks and should not be very expensive.
- It should have proper adhesion with the surfaces.

Heat Insulating Material

Heat insulating material are used for preventing or retarding transmission of heat or cold. Various insulating material are used for air conditioning of buildings and railway coaches. Thermal insulation in buildings results in comfortable living and working indoor conditions. Commonly used heat insulating material include rock wool, slag wool, cork board slabs mineral wool, fibre boards, saw dust, flexible blankets, wood savings, gypsum boards, AC boards, chip boards, foam glass, cork seat and cement concrete products. A good thermal insulating material should not absorb moisture and it should be able to resist the attack of insects. It should be fire proof. Some heat insulating materials are available in market on the patented trade names of Masonite, Indianite and Feathercrete, etc.

Asbestos

Asbestos cement is the combination of asbestos fibre and cement. It is commonly used for making roof sheets and pipes. Asbestos cement boards are prepared by moulding the mixture of asbestos fibre and cements under pressure.

Thermocol

Thermocol is light cellular material and acts as good electric insulator. It is strong, durable and damp-resisting material. It is also used to provide acoustic treatment in buildings and for packing purposes.

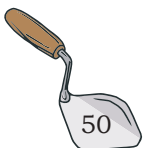

Sunglass

Sunglass is transparent plastic just like glass. It does not shatter on breaking. Styrene and Perspex are some varieties of sunglasses. It is widely used in aircraft and car industries for safety purpose. Lens is also made from sunglasses.

Abrasives

An abrasive is a hard and sharp material used to remove excess of materials by grinding or rubbing action. Emery is brownish in colour. It is cheap and widely used in the form of coarse, medium and fine grains in grinding wheels, polishing glass, emery cloth, emery paper and for making coated papers. Flint is an opaque variety of quartz. It is used for tipping glazier's diamond. Sand stone is found in India in various grain sizes and hardness. It is widely used as grinding stones in flour mills and pulp stones for shredding paper in paper mills. It is also used for polishing floor slabs. Grinding wheel is prepared by bonding abrasive powder on the cast iron wheels using suitable adhesives. Carborundum is an artificially prepared polishing abrasive. It is used for making grinding wheels, hard alloys, stones and glasses, etc. and for polishing cement concrete floors.

Adhesives

Adhesives are the substances which are used to join two or more parts to form a single unit. They are extensively used in manufacture of plywood, laminated glasses and laminated plastics, etc.

Linoleum

This is prepared by fixing a paste containing mixture of ground wooden cork, colouring pigment, wood flour and linseed oil on canvas or tate. Linoleums are durable, hygienic, resilient, warm, attractive and expensive floor coverings. Special linoleums are also available for wall coverings.

Rubber

Rubber is a bad conductor of heat. It can absorb shocks or impacts and can be extended by applying force.



Fig.2.22: Adhesive

Rubber is used for tyres of vehicles, gaskets, rubber ropes, shock absorbents, lining for reservoir and thermal insulation, etc.

Glass Wool

This is obtained by spinning out the thin fibres of glass in molten state. Glass wool is available in the forms of loose fiber, quilts, mats and rigid and semi-rigid slabs. It is used as filter in air conditioners. It is also used for heat and electric insulation.

Mica

Mica is a naturally occurring mineral made from the collection of silicate minerals, composing varying amounts of potassium, iron, aluminium, magnesium and water.

Coal Tar

Coal tar is a thick dark liquid, which is a by-product of the production of coke and coal gas from coal. These are obtained by distillation of respective materials. Crude coal tar is used for coating wooden poles, sleepers, iron poles, latrine walls and finishing nets, etc. Mineral tar is used for water proofing. Tar is also used for road making. Coal tar pitch is used for water proofing in concrete structures, flooring mastics and as base for coaltar paints.

Ferro cement

Ferro cement is highly versatile construction material which is widely being used nowadays. It is a composite



Fig.2.23: Ferro Cement work

material comprising cement-sand mortar reinforced with welded wire mesh and chicken mesh. Ferro cement products can be fabricated into any desired shape to meet the needs of the user. It does not need any expensive plant or machinery. However, ferro cement construction is labour intensive. Ordinary portland cement, sand and wire meshes having 0.5-1.0 mm diameter and 10-25 mm mesh opening have been successfully

used for many ferro cement constructions. Ferro cement

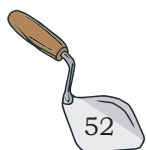

is generally used for low-cost housing, water storage tanks, economical toilet, bathroom units, grain storage silos of varying capacities and exploitation of alternate energy sources, etc.

NOTES

Practical Activity

1. Visit the local market for survey of the following materials used in the building construction.
 - (a) Bricks
 - (b) Cement
 - (c) Aggregate
 - (d) Tiles
 - (e) Paint
 - (f) Distemper
 - (g) Varnishes and polishes
 - (h) PVC fittings in plumbing
 - (i) Sand
 - (j) Glass for door and window
2. Visit the following manufacturing units
 - (a) Brick manufacturing unit
 - (b) Tile manufacturing unit
 - (c) Stone crusher
 - (d) Precast manufacturing unit
 - (e) Metal grill fabrication manufacturing workshop
 - (f) Wallpaper and flooring mat shops
 - (g) Cement manufacturing plant
 - (h) PVC pipe manufacturing unit
 - (i) Glass manufacturing unit

Check Your Progress

A. Fill in the blanks

1. Bitumen is _____ type of material.
2. Wiremesh used in ferro cement is of _____ mm diameter.
3. Types of plastic are _____ and _____.
4. Plastic products are light _____ and provide sufficient _____ and corrosion _____ property.
5. Glass absorbs and reflects _____.
6. An abrasive is a _____ and sharp material used to remove _____ of materials by grinding or rubbing action.
7. Rubber is _____ conductor of heat.
8. Adhesives are the substances which are used to join _____ or more parts to form a _____ unit.
9. Mica is found in the form of thin sheets and widely used for _____ insulation.

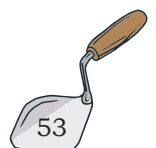

NOTES

B. Write short notes on

1. Linolium
2. Rubber
3. Coal tar
4. Plastic
5. Adhesive
6. Glass
7. PVC
8. Damp-proofing material

C. Multiple choice questions

1. Which thermoplastic resin provides light and tough sheets?
(a) Perspex (b) Alkathene
(c) PVC (d) Polyethylene
2. Mica can be used for _____.
(a) thermal insulation (b) sound insulation
(c) electrical insulation (d) None of these
3. Which of these is a bad conductor of heat?
(a) Mica (b) Rubber
(c) Glass wool (d) Linoleum
4. Which among these is a good electric insulator?
(a) Thermocol (b) Sunglass
(c) Asbestos (d) PVC

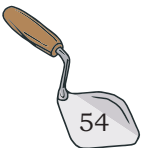

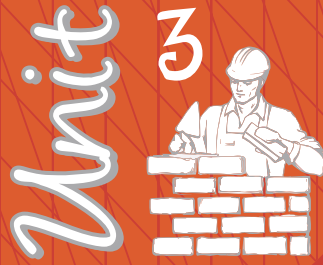

Units of Measurements used in Civil Works

In any work, especially civil, in the planning and execution, measurement of the item plays an important role. At various places the method followed for the measurement is not uniform and slight ambiguity may lead to serious financial differences between the states. Sometimes, even in the same state different departments follow different methods. To standardise the methods of measurement of building and other civil engineering work IS:1200 (part I to XXV) has been framed by the Indian Standard Institution and hence in case of any discrepancy this IS: 1200 must be adhered to.



General Rules

1. Measurement shall be item wise and each item shall be fully described so that the work involved in item is self explanatory.
2. In booking dimensions, the order shall be in the sequence of length, breadth, height or depth or thickness.
3. All work shall be measured not subject to the tolerances unless otherwise stated.
 - (a) Dimension shall be measured to the nearest 0.01 meter i.e to 10 mm–1 cm
 - (b) Areas shall be measured to the nearest 0.01 sq.m.
 - (c) Cubic contents shall be worked up to the nearest 0.01 m

NOTES

4. Same type of work under different conditions and nature shall be measured separately under separate items.
5. The bill of quantities shall fully describe the item with materials, proportions, workmanship, etc.

Let us discuss the various items of work, especially of buildings, as regards to the units of measurement and payment. These are required for the preparation of estimates and finding out the cost and for actual payments after execution.

Excavation

The item of excavation is charged at the rate of per cubic metre and hence length, width and depth are measured. The length and width are measured as per the exact dimensions given on the drawings by the engineer. The depth is measured vertically at number of places and mean value is taken. No allowance is given for the working space. For large variations in depths, the area is divided into suitable sections and different depths are obtained for each section.

Lead and lift

Measurement for excavation for every 1.50 m. depth is taken separately. Similarly, for different leads also, the measurements are taken separately. First lead to 50 m and lift of 1.50 m is included item. For further unit of lead and lift extra payment may be given. The lead should be measured from the centre of the area of excavation to the centre of area of the spoil heap. Similarly, lift should be measured from the centre of the excavation to the centre of the spoil heap.

Concrete

Concrete in general is also measured in cubic meters. Foundation concrete should be measured in cubic metre (cum), the length and width being same as in excavation. Depth is measured as per actual concrete laid.

RCC Work

Reinforced cement concrete (RCC) and plain cement concrete shall be taken separately but in cu.m. The

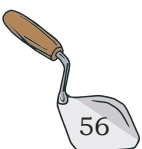

volume of reinforcement shall not be deducted. RCC Lintels, beams, columns shall be measured in cu.m. The ribs of beam projecting above or below the slab shall be taken for beam measurement. Height of column shall be measured upto the bottom of the beam.

RCC slabs upto 100 mm thickness, RCC *pardi*, partition walling *chhajja* shall be measured in square meters. RCC stair is measured in terms of numbers of steps. Half landing and quarter landing being taken as equivalent to four and two steps respectively. Damp proof course shall be taken in square meters with full description. Precast cement concrete work shall be taken in square meters with thickness specified for *jalli* work and louvers and in cu.m. meters for other cubical parts.

Brickwork

Brickwork is also measured in cubic metres for one brick wall and more thickness. Half brick wall and less than half brick wall should be measured in square metres. Brick work for arch should be measured separately in cubic metres. Walls are treated as solid without any opening, such as windows, doors, etc., for measurements. Then the deductions are made for all openings about 10% of the total calculated work.

No deduction or addition shall be made for the following:

- a) Opening up to 0.10 sq.m. in section
- b) Ends of joist, beams, lintel, posts rafters, purlins, corbels, steps, etc.
- c) Wall plates, bed plates, bearing plates, *chhajjas* and where the thickness does not exceed 10 cm and the bearing does not extend over the full thickness of wall.

Following special items of brickwork shall be measured separately — fire places, chimneys, etc., Pillars, arches, wall staining, reinforced brickwork, etc., shall be measured in cubic metres. Honeycomb brickwork, partition walls, should be measured in square metres. Moulding, cornices, string course, drip coarse, etc., should be measured in running metres.

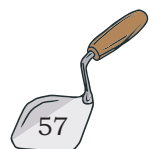

NOTES

Toothing and bonding in square metre measured on the vertical face.

Stone Masonry

The stonework is measured in cubic metres. The full description regarding stone, mortar, proportion, etc. shall be given. Each type of stone masonry shall be taken separately. The thickness of wall should be measured to the nearest 10 mm. Deductions shall be same as in the item of brickwork. Stonework for the sill and copings of parapet shall be measured in running metres. The stonework for shelves, weather sheds and slabs shall be measured in square metres.

Woodwork

In case of woodwork the type of timber to be used and quality of finish to be used should be clearly mentioned in the item. The rate shall include fabrication, fixation, fastening, fixtures and three coats of oil paint.

The measurements are taken of the net work done and no consideration is given to the wastage of the material with a tolerance of 2 mm.

Steel and Iron Work

The unit in general is by weight, i.e. kg, quintal or tonne, and with full descriptions. Various items will be Rolled Steel Joist (RSJ), steel sections, structural steelwork, bolts, steel reinforcement, etc.

Roof Coverings

In general the unit is square metre (sq.m.), without any allowance for laps. Openings up to 0.40 sq.m. shall not be deducted. Ridges and hips shall be measured in running metre. Even the corrugated roofing shall be measured in sq.m. flat, not girthed.

Flooring and Pavings

These shall be measured in sq.m. with separate items for various types of floor finishes or pavings.

Skirting and dado

Up to 300 mm in height is measured in running metre and exceeding 300 mm in sq.m.

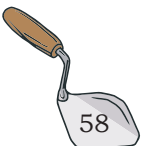

Plastering

Plastering is measured in sq.m. stating thickness, mortar and mix. External plasters shall be measured in stages of 3 m height. Plastering band 300 mm or below shall be measured in running metres.

Deductions

Rules that need to be followed are:

- a) No deductions will be made for ends of joist, beams, posts, etc. and openings not exceeding 0.5 sq.m. each and no additions will be made for reveals, jambs, soffits sills etc. of these openings not finishing plaster around ends of joists, beams, posts, etc.
- b) For opening exceeding 0.50 sq.m. but not exceeding 3 sq.m each deduction will be made for one face only and the other face will be allowed for jambs, soffits, sills which shall not be measured.
- c) When two faces are plastered with different mortar or if one side is plastered the other pointed, deduction will be made on the side of *chaukhat* of doors or windows on which the width of jambs or reveals is less than on the other side (Usually deduction is made for the outer face only).
- d) In case of openings of area 3 sq.m. each deduction shall be made for both faces of the openings and the jambs, reveals, soffits and sills shall be measured and added. In taking measurements of jambs, reveals, soffits and sills, *chaukhat* if any shall be neglected and the whole face shall be measured.

Moulded cornices, etc. shall be measured in running metres.

Pointing

Pointing will be taken in square metres and measured flat of the whole surface area. Deductions will be dealt in the same way as for plastering.

White Washing, Colour Washing and Distemping

All the works will be measured in sq.m. preparation of surface, cleaning etc. will also be included in the

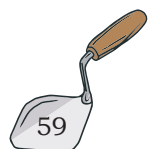

item which includes path or spot repairs not exceeding 0.10 sq.m.

Deduction rules shall be the same as for plastering.

Multiplying factors for adding to the flat measurements of corrugated surfaces.

- Corrugated iron sheets — 14%
- Corrugated Asbestos cement sheets — 20%
- With large corrugations (viz. Big Six) — 10%
- Semi corrugated asbestos cement sheets (Viz. Trafford Sheets) — 10%

Painting

Painting will be measured in sq.m. stating number of coats and measured flat. The items include the preparation of surface, cleaning, rubbing, etc.

Corrugated surface will be dealt with same as white washing. Painting of doors and windows will be measured, closed and flat in sq.m.

The coefficients or multiplying factors for different surfaces to get equivalent plain area are as given below.

Coefficients or multiplying factors for different surfaces

S.No.	Doors and Windows	Multiplying factors
1.	Panelled, Framed and Braced Ledged and Battened, Ledged Battened and Braced	1.125 each side
2.	Fully glazed or gauged	½ for each side
3.	Part panelled and glazed or gauged	1 for each side
4.	Flush doors	1 for each side
5.	Flush venetioned or louvered miscellaneous works	1.50 for each side
6.	Roof battens (openings not to be deducted)	for all over ¾
7.	<i>Jaffri</i> work one or two way	2 for all over (No deductions for opening)
8.	Balustrades, grills, grating, railing,	1 for all over x-per meter (No deduction for opening)
9.	Steel Rolling shutters	1.25 for each side
10.	For corrugated iron, asbestos sheets, etc., same as for white washing, etc.	1.14 1.10 1.20 For each side



Painting upto 150 mm in width or in girth will be measured in running metre.

Painting trusses, compound girders, and other such works will be measured in sq.m. and measurement of perimeter and length shall be taken to get the area.

Painting on eaves, gutters, pipes, poles, etc. shall be measured in running metre.

Coal tarring, varnishing and polishing shall be measured similar to painting.

List of Units of Measurements and Payments for Various Items of Work and Material in a Tabular Form

Let us summarise and prepare the list of units of measurements and payments for various items of work and material in a tabular form.

Description	Units of	
	Measurement	Payment
1	2	3
Earth work		
1. Earth work in excavation for foundation in all sorts of soil	cu.m.	Per cu.m.
2. All types of filing in plinth and elsewhere	cu.m.	Per cu.m.
Concrete		
1. Plain or Reinforced cement concrete lime concrete for almost all component parts	cu.m.	Per cu.m.
2. Thin RCC members viz. slab, <i>pardis</i> etc.	sq.m.	Per sq.m.
3. Damp Proof Courses (DPC)	sq.m.	Per sq.m.
Brickwork		
1. Brickwork in general for foundation, plinth, super structure etc.	cu.m.	Per cu.m.
2. Brickwork for half brick walls and thinner walls	sq.m.	Per sq.m.
3. Lengthwise courses, such as string course, drip, weather courses cornice, etc.	Intre	Per m.
Stonework		
1. Stone masonry UCER, CR and all types	cu.m.	Per cu.m.
2. Cut stone work in lintel, beams, etc.	cu.m.	Per cu.m.
3. Stone slabs in roof, shelves wall	sq.m.	Per sq.m.

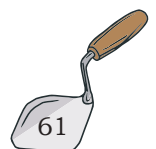

Woodwork		
1. Woodwork for doors and windows frames, roof, components of trusses, wall plate etc.	cu.m.	Per cu.m.
2. Door and window shutters, partition, plywood etc.	sq.m.	Per sq.m.
3. Ballies specifying diameter	m.	Per m.
Steelwork		
1. Almost all steelwork viz. RSJ various sections, Reinforcement bars etc.	Quintal or tonne	Per q.T. (by weight)
2. Grillwork, X-pm, collapsible, rolling shutter doors and windows	sq.m.	Per sq.m.
3. Railing CI pipes	m.	Per m.
Roofing		
1. Roofing in general viz. tiled roof, cl, or asbestos, sheeting, eaves board, ceiling	sq.m.	Per sq.m.
2. RCC slabs	cu.m.	Per cu.m.
3. Ridges, valleys, gutters, etc.	m.	Per m.
Plastering, pointing and finishing		
1. All in general	sq.m.	Per sq.m.
2. Skirting upto 300 mm ht.	m.	Per m.
Flooring		
1. All types of flooring	sq.m.	Per sq.m.
Material		
1. Supply of bricks	1000 nos.	Per 1000 nos.
2. Supply of sand, muram, metal timber, etc.	cu.m	Per cu.m.
3. Supply of cement and lime	Bag or by weight	Per bag per quintal or Ton
4. Supply of steel, .GI Sheets	Quintal	Per quintal
5. Supply of electrical units such, as switches, plugs, bulbs, brackets, etc.	Number	Per no.
6. Supply of sanitary units and water supply units such as wash basin, sinks, WC pans, Taps, valves, etc.	Number	Per no.
7. Supply of pipes – CI S.W. AC, etc.	Metre	Per m.
8. Supply of paint, varnish oil etc.	Litre	Per L.

Note: Sq. m. = Square metre, Cu.m. = Cubic metre

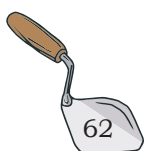

Practical Activity

1. Measure the different items of a single room with measuring tape or any other measuring tool and record in a tabular format.

Check Your Progress

A. Write down the units used for the following items of work

1. Earthwork in excavation
2. Brickwork in superstructure
3. Railing CI Pipes
4. Flooring
5. Stone masonry
6. Skirting
7. Supply of paint
8. Frames of doors and windows
9. Wooden stairs
10. Plastering and Pointing
11. Steel reinforcement
12. Damp proof course

B. Fill in the blanks with appropriate measurement units

1. Wooden beams and posts, rectangular in section _____.
2. Frames of doors, windows, cupboards, ventilators etc. _____.
3. Component parts of wooden trusses _____.
4. Shutters of doors, windows etc. _____.
5. Roof battens _____.
6. Ballies, cornices, picture rails, architraves etc. _____.
7. Wooden stairs _____.

C. Multiple choice questions

1. The rate of an item of work depends upon _____.
(a) Specification of work
(b) Specification of materials
(c) Proportion of mortar
(d) All of these
2. Brick wall is measured in sq.m. if thickness of wall is _____.
(a) 15 cm (b) 10 cm
(c) 20 cm (d) None of these
3. While estimating the quantities for the construction of a building the correct metric unit is _____.
(a) metre for length (b) cubic metre for area
(c) square metre for volume (d) litre for capacity

NOTES

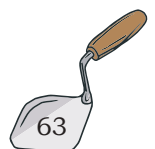

NOTES

4. The brickwork is not measured in cu.m. in case of _____.
- (a) one or more than one brick wall
 - (b) brick work in arches
 - (c) reinforced brick work
 - (d) half brick wall
5. Which of the following item of earthwork is not measured separately?
- (a) Setting out of work
 - (b) Site clearance
 - (c) Steps in deep excavation
 - (d) All of these
6. The measurement is made in square metre in case of _____.
- (a) cement concrete in foundation
 - (b) RCC structure
 - (c) hollow concrete block
 - (d) None of these
7. Up to _____ height of dado is measured in running metre.
- (a) 300 mm
 - (b) 330 mm
 - (c) 315 mm
 - (d) 325 mm

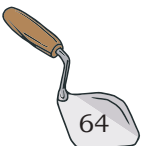



Handling of Basic Masonry Tools



17922CH04

While carrying out the masonry work, mason requires different types of tools. In stone masonry, tools are categorised as dressing tools and masonry construction tools. Stones are available in irregular size and shape. As per the construction requirements, to make them of regular size and shape and to form correct shape, following tools are used by the stone dresser and mason.

Types of Masonry Tools

Following are the various types of tools used to carry out masonry work.

- (i) **Plumb rule and bob:** is used to check the verticality of the wall, column, wooden frame i.e. door, window etc. It consists of a two-metre long wooden piece whose top portion is attached to a plumb bob. (Fig.4.1).
- (ii) **Spirit level:** is used to check the horizontality of the floor, roof, door, window frame etc.(Fig.4.2)
- (iii) **Trowel:** is used to lift and spread mortar to form the joints and to cut the bricks.

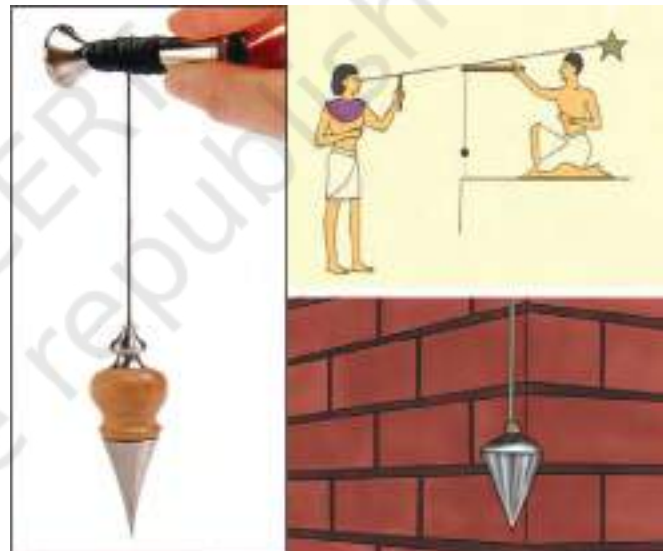

Fig.4.1: Plumb Bob



Fig.4.2: Spirit Level



Fig.4.3: Trowel



Fig.4.4: Square



Fig.4.5: Line and Pins



Fig.4.6: Chisel



Fig.4.7: Bolster



Fig.4.8: Mash Hammer

It is made of steel blade, shank and wooden handle (Fig.4.3).

- (iv) **Square:** is right angle steel piece, which is used to check the right angle (perpendicularity) of the walls, columns etc. (Fig.4.4)
- (v) **Line and pins:** are used to maintain the alignment of the work in progress i.e. brick or stone masonry. It consists of good quality thread and two pin (Fig.4.5).
- (vi) **Chisel:** is used to dress the stones. Chisels are of different shapes and sizes, and are used for different stone cutting and dressing works (Fig.4.6).
- (vii) **Bolster:** is used to cut the bricks accurately. The main part of bolster is a steel wide blade (Fig.4.7).
- (viii) **Mash hammer:** is used to dress the stones (Fig.4.8).

- (ix) **Scabbling hammer:** is used for breaking the small projection of the stones (Fig.4.9).

- (x) **Bevel:** is used to set the angle of the stone, brick machinery, flouing, projections, etc. It consists of two steel blades having slots and fixed together by a thumbscrew. These two blades can be set at any desired angle(Fig.4.10).

- (xi) **Spade:** is used to lift the sand, soil, mortar etc. It is also used in excavation of soft soil (Fig.4.11).

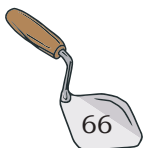



Fig.4.9: Scabbling hammer



Fig.4.10: Bevel



Fig.4.11: Spade

- (xii) **Hacking tool:** the plain surface of the concrete is roughened by hacking tool. It is in the form of a hammer with chisel head or point head. The head is made of mild steel and pointed edge is made of tool steel (Fig. 4.12).
- (xiii) **Pickaxe:** is used for rough dressing of the stones and to split stones in a quarry (Fig. 4.13).
- (xiv) **Crowbar:** is used to make stones in a quarry (Fig. 4.14).
- (xv) **Wooden float:** is used to spread the mortar on the surface. It is also used to finish the coat of plaster. It is made of wood (Fig. 4.15).



Fig.4.12: Hacking tool



Fig.4.13: Pickaxe



Fig.4.14: Crow bar



Fig.4.15: Wooden float

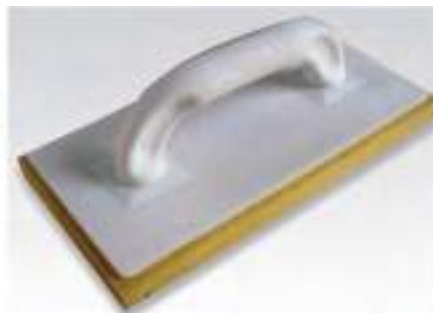

Fig.4.16: Metal float



Fig.4.17: Racking needle



Fig.4.18: Scratcher



Fig.4.19: Spall hammer



Fig.4.20: Mortar pan



Fig.4.21: Pointing tool

(xvi) Metal float: is used for laying the mortar as well as to obtain the desired surface finish (Fig. 4.16).

(xvii) Picks and beaters: they are available with double point ends, point end and narrow chisel, point end and wide chisel, etc., having weight 3, 3.2 and 4 kg. Beaters are available in tee-end and square with point ends, which weigh 3.6 and 4.1 kg.

(xviii) Floating rule: is used for checking the level of the plastered surface between the successive screeds.

(xix) Racking needle: for plastering the brick wall, the joints of the brickwork are cleaned to about one centimetre in depth. This process is called racking. The tools used to remove the joint material is called racking needle (Fig. 4.17).

(xx) Scratcher: is used to scratch the surface of partially set plaster in the undercoat to provide a key for the following coat. These are of two types: fan and comb. (Fig.4.18).

(xxi) Pointing tools (Naylas): are used for pointing of the stone masonry. They are of three types—small, medium and large. The small *nayla* is

used for vertical joints. For horizontal joints, the long *nayla* first is used to align the joints straight and then the medium size *nayla* is used (Fig.4.21).

- (xxii) **Mortar pan:** is a hallow pan made out of pressed mild steel 1 to 1.5 mm thick with edges folded all round. It is used for handling and conveying cement, mortar, sand, etc. (Fig.4.20).
- (xxiii) **Brick Hammer:** is used to cut the brick into different shapes and sizes. One end of the hammer is a square and other end is sharp edged.
- (xxiv) **Scutch:** is device to dress the cut bricks and for cutting soft bricks.
- (xxv) **Spall hammer:** is a heavy hammer used for rough dressing of stone.(Fig.4.19).

Precautions

- (i) The tools should be stored in order in a place or rack.
- (ii) The tools should not be subjected to continuous dampness, moisture, etc., otherwise the trowel, flat and mortar pan may be damaged by rust.
- (iii) During use and transportation, the tools should not be dropped, otherwise, teeth may get damaged.
- (iv) While working at height, precautions should be taken, so that either the tools or the material should not fall on anybody standing or moving below in that area.
- (v) After the work the tools need to be cleaned and washed with water, especially those handling mortar, concrete etc.

Practical Activity

1. Identify masonry tools available in your class workshop, draw them in your notebook, note down the price and manufacturer's name.

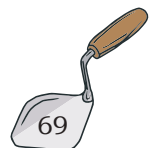

NOTES

Check Your Progress

A. Fill in the blanks

1. Trowel is used to _____ and spread the _____.
2. The plumb rule and bob is used to check the _____ of the wall.
3. Chisels are used to _____ the stones.
4. A bolster is used to _____ the bricks accurately.
5. Mortar pan is used for handling and _____ cement, mortar, sand, etc.
6. A spirit level is used to check the _____ of the floor, roof, door, window frame, etc.
7. A square is a right-angled steel piece, which is used to check the _____ of the walls, columns, etc.

2. Draw the figure of the tools given below in your notebook.

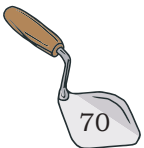
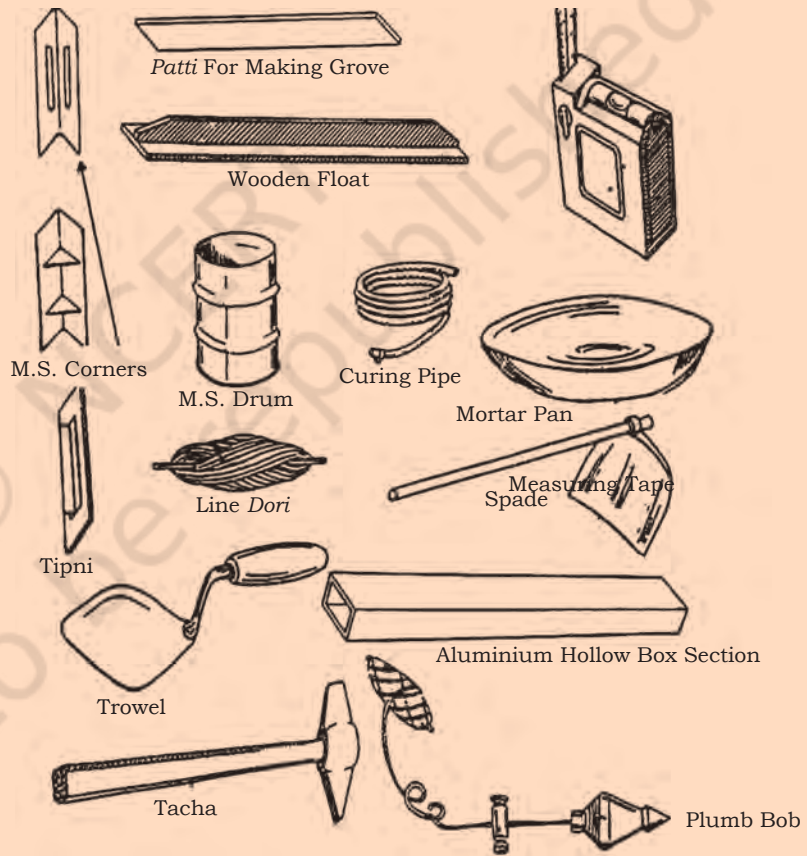

Unit

5



Marking of Line

Marking of line is the first important work after the cleaning and levelling of a site. By reviewing or studying the foundation plan of a building structure, marking of the centre of the foundation is done with lime powder. For that, firstly the boundary of the plot is fixed with wooden bamboo planks.

Certain markings are done on the ground before the excavation of the foundation is actually started.



17922CH05

Process of Line-out

The line-out process serves as a guide and provides checking of construction of the foundation work.

Tools required

1. Line *dori* or thread
2. *Gamla* or iron pot
3. Wooden or steel pegs
4. Hammer
5. Spade
6. Trowel
7. Plumb bob
8. Pickaxe
9. Mason square

Raw material

Lime powder, bricks, cement, sand

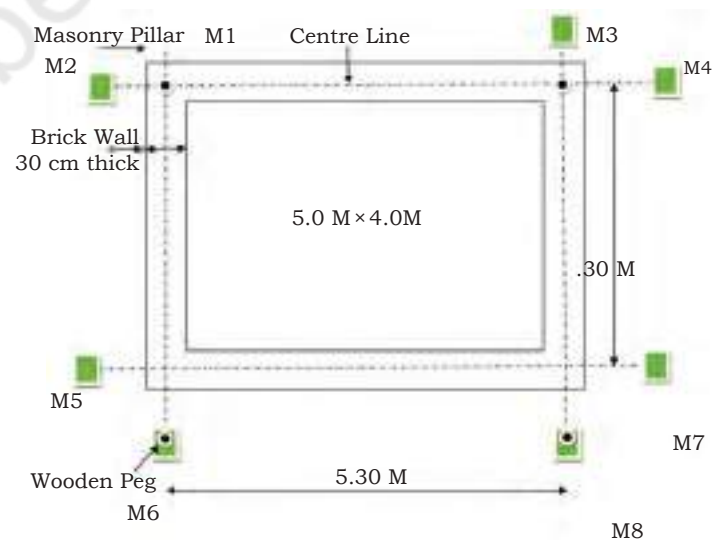

Fig. 5.1: Foundation Plan

Procedure

1. From the site plan, one line (A-A”) may be established and selected. This may be used as a base line for the entire work. (Fig. 5.1)
2. Then at the centre, a line of wooden pegs shall be driven on the ground.
3. Two wooden pegs are driven at an equal distance on either sides of the centre line peg equal to the width of foundation trench.
4. Thread or line *dori* shall be tied with the rest of the pegs. Now lines are marked with the help of pick-axe.
5. Line powder should be spread along these lines.
6. Along centre line pegs, masonry pillar(MP1) (one brick \times one brick) shall be constructed at a distance of approx. 2 metre from the centre line. (Fig. 5.2)
7. These pillars are kept in height up to plinth level and plastered.
8. Same process is followed for marking the four corners of centre line of foundation plan.

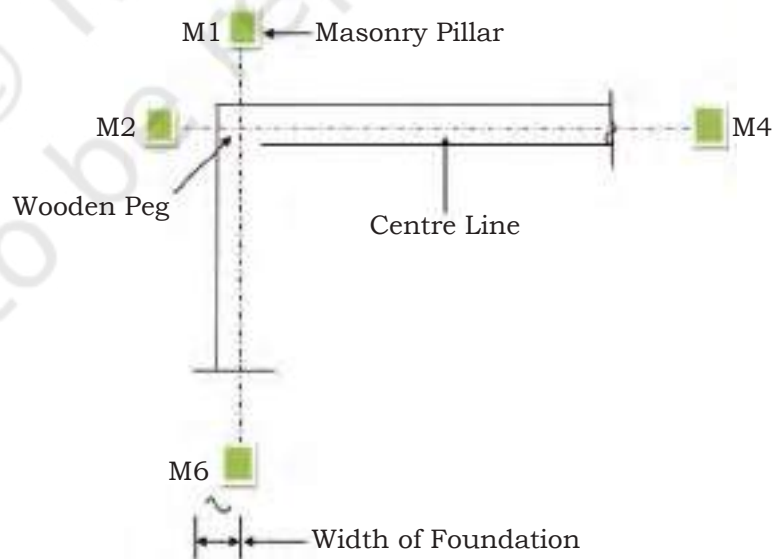
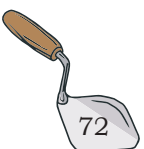

Fig.5.2 : Line-out for Foundation



Practical Activity

1. Mark the line-out of foundation for one room building

Check Your Progress

A. Answer the following questions

1. Which tools are used for line-out for foundation plan? Explain with sketch.
2. Write down the procedure for marking line-out for foundation on ground.

NOTES

© NCERT
not to be republished

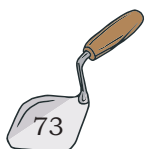

Unit

6

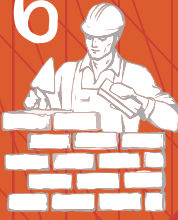

Building Drawing



17922CH05

Before constructing any building, detail designing of all the components are made on paper and then transmitted into drawing. Drawings are made on paper as per the standard procedure. This drawing helps workers, engineers and users in understanding and planning the construction work.

SESSION 1: BASIC GEOMETRIC CONSTRUCTIONS

The understanding of plane geometry is pre-requisite for the proper use of geometric constructions. The students, during making geometric constructions develop skills in handling drawing tools (compasses and dividers, triangles, rulers, templates) and promote logical thinking. Engineering drawing consists of many such geometrical constructions. To record information on paper or any other surface, instruments and equipment are needed, since engineering drawing is a representation of the graphical language.

List of essential instruments and equipment for geometrical constructions and drawing

1. Drawing board and stand
2. Tee-square

3. Mini drafter
4. Set square
5. Protractor
6. Instrument box
7. French curves or irregular curves
8. Pencil
9. Eraser and erasing shield
10. Blade, pocket knife, or pencil sharpener
11. Drawing pins, adhesive tape, or clips
12. Drawing paper or drawing sheet, tracing paper, and tracing cloth
13. Cloth or brush for dusting
14. Sand paper
15. Scales (engineering scales)
16. Sketch book

You must have used some of the above instruments in your earlier classes but the important ones are shown in Fig.6.1.

1. Large size compass (150 mm long) with inter-changeable legs for pen or pencil
2. Large size divider (150 mm long)
3. Small bow compass (95 mm long)
4. Small ink bow compass (95 mm long)
5. Small bow divider (95 mm long)
6. Lengthening bar
7. Pin point
8. Ink point
9. Ruling pen or liner

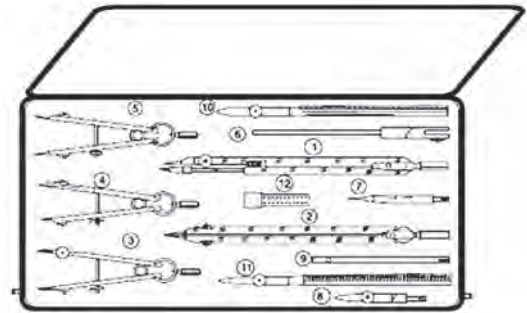

Fig.6.1: Drawing an Instrument box

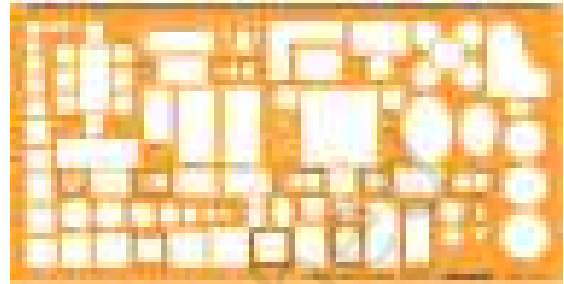

Fig.6.2: Template

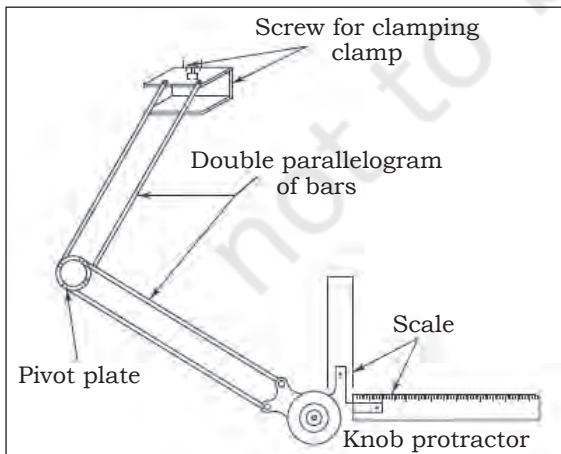

Fig.6.3: Mini drafter

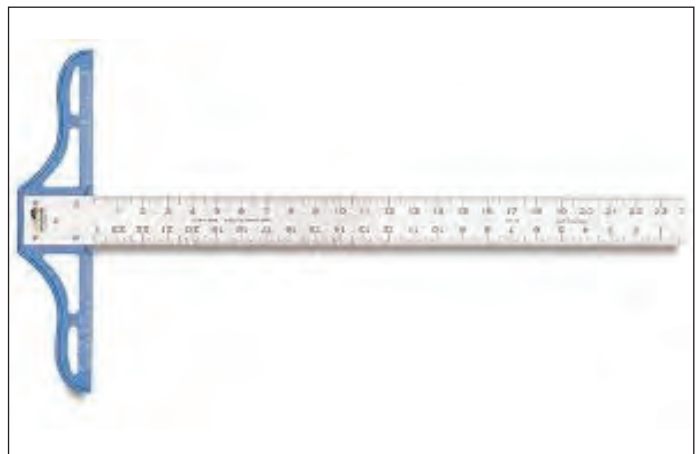

Fig.6.4: Tee-square

- 10. Holder croquill (for lines)
- 11. Lead case (for storing lead)

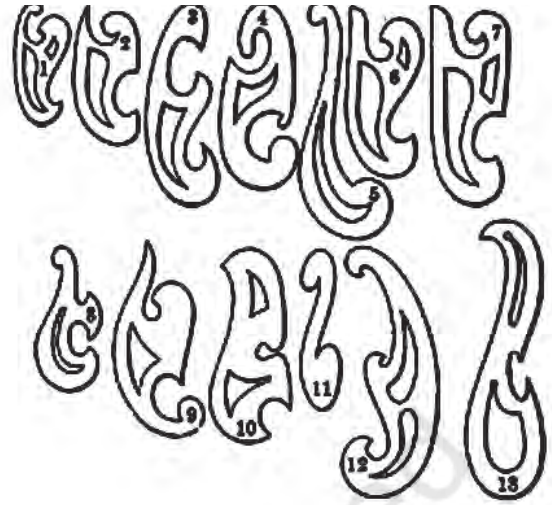
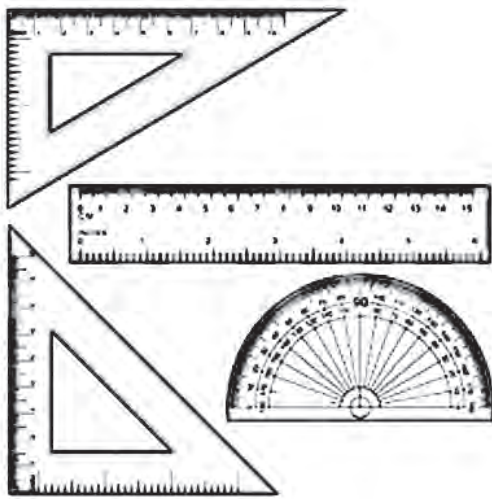

Fig. 6.5: Set squares, scale, protractor and set of French curves

Methods of Geometrical Constructions

Problem 1

Bisect a given segment of a line AB.

Solution: (Fig.6.6)

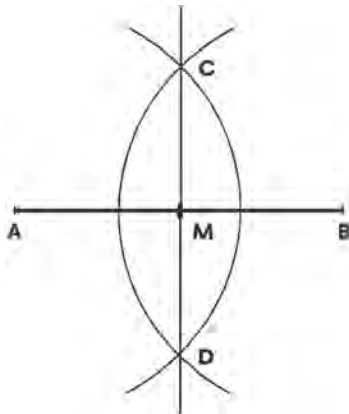

Fig.6.6: Bisecting a line

1. Using a scale or ruler, draw a line AB of given length.
2. Set a compass more than half the length of AB, and using A as the centre draw arcs as shown in the figure.
3. Draw arcs using B as the centre with the compass set as above.
4. Connect the intersection (C and D) by a line.
5. The connecting line bisects AB in point M.

Problem 2

Bisect a given angle.

Solution: (Fig. 6.7)

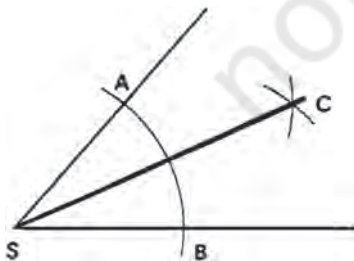
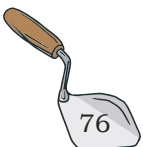

Fig.6.7: Bisecting an angle

1. Draw any acute angle.
2. To obtain points A and B on the lines, draw an arc with S as the centre.
3. Using A and B as the centres draw arcs which intersect on point C
4. The connecting line C-S bisects the angle.



Problem 3

Constructing an angle of 60° .

Solution (Fig.6.8)

1. Using a scale or ruler draw a straight line and mark point A on it as shown in the figure.
2. Open compass to a suitable length, place needle of the compass on point A and draw an arc, thus intersecting the line at point B.
3. Keeping the compass opening same, place the compass needle on point B and draw an arc intersecting the previous arc at point C.
4. Join AC. Angle BAC is required angle of 60° .

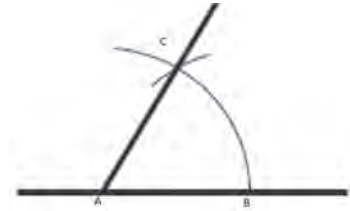

Fig.6.8: Constructing an angle of 60°

Problem 4

Constructing an angle of 30° .

Solution (Fig.6.9)

1. Construct an angle ABC of 60° .
2. Open a compass; draw an arc by placing the compass needle at point C. Similarly draw an arc by placing the needle at the point B thus intersecting the arc at point D.
3. Join AD, Angle DAB is of 30° , i.e. half of 60° .

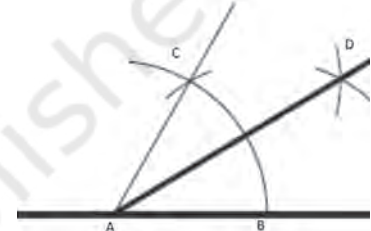

Fig.6.9: Constructing an angle of 30°

Problem 5

Constructing an angle of 90° .

Solution (Fig.6.10)

1. Using, scale or rulers, draw a straight line. Mark point A on it.
2. Open compass to a suitable length, place the compass needle at point A and draw an arc intersecting the line at point B. Do not change the opening of compass for the next steps.
3. By placing the needle at point B intersect the arc at point C.
4. Similarly, place the compass needle at point C, intersect the arc at point D.
5. Taking centre C and D draw arcs intersecting at point E. Join AE.
6. Angle BAE is of 90° .

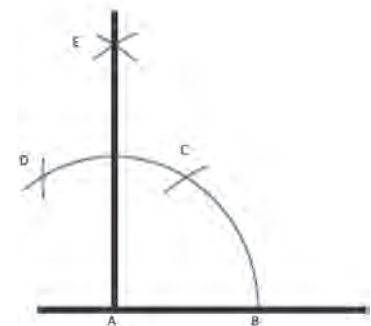

Fig.6.10: Constructing an angle of 90°

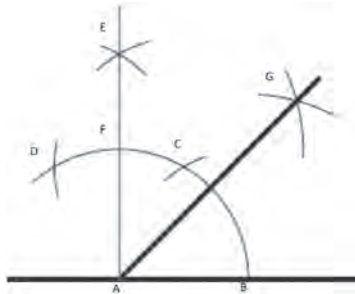

Fig. 6.11: Constructing an angle of 45°

Problem 6

Constructing an angle of 45° .

Solution (Fig. 6.11)

1. Construct an angle BAE of 90° .
2. Open a compass and with centre point as B and F, draw arcs intersecting at point G.
3. Join AG. Angle BAG is of 45° .
4. It is bisector of 90° angle.

Problem 7

Draw a perpendicular line to the line AB at point A.

Solution: (Fig. 6.12)

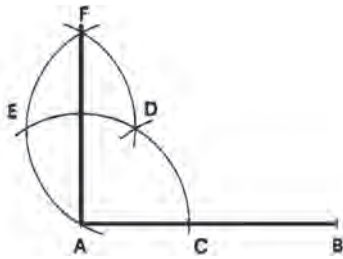

Fig. 6.12: Drawing a perpendicular to a given line

1. Using a scale draw a line AB. The perpendicular to this line is to be drawn at point A.
2. Set the compass to any radius and do not change it in further steps.
3. Draw an arc about A as centre, thus obtain a point C on the line AB.
4. Draw an arc about C as centre, thus obtain point D.
5. Draw an arc an arc about D as centre, thus obtain point E and it also touch line at point A.
6. Draw an arc about E as centre, thus obtain point F.
7. Connecting line F to A is the perpendicular.

Problem 8

Divide a given line into 5 equal parts.

Solution: (Fig. 6.13)

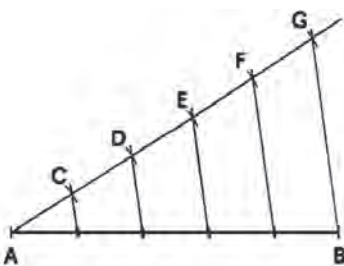
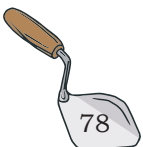

Fig. 6.13: Dividing a given line in equal parts

1. Using a scale draw a line AB. This line is to be divided into equal parts.
2. From A of this line draw a second line at any convenient angle.
3. Open a compass to suitable length and divide the second line into 5 equal spaces (points C-G) without altering the compass opening.
4. Connect G with B.
5. Using set squares draw parallel lines to GB from all the points (points F-C) as shown in the figure.
6. Thus the line AB gets divided into 5 equal parts.



Problem 9

Drawing parallel lines by compass.

Solution (Fig.6.14)

1. Using a scale draw a straight line AB and extend it to both sides.
2. Open compass to a desirable length, place the compass needle at point A on the line and draw an arc as shown in the figure.
3. Do not alter the compass opening and draw similar arc from the point B on the line.
4. Mark the highest points on the arcs as C and D.
5. By using scale or ruler, join points C and D and extend the line to both sides. The line CD thus obtained by joining the points is parallel to the line AB.
6. In case the parallel line is to be drawn which passes through the point C, then draw perpendicular from point C to the line meeting at A. Set compass opening equal to the length of perpendicular CA, draw an arc from the point B and mark highest point or point of tangency on the arc D and join CD. Alternatively a perpendicular can be drawn from point B and cut this perpendicular to same length as CA to obtain point D.

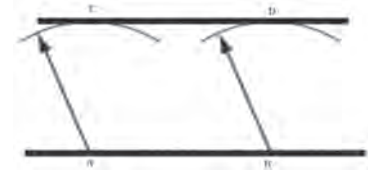

Fig.6.14: Drawing parallel lines

The Triangle

Definitions

A plane figure surrounded by three straight sides forms a triangle.

- A scalene triangle is formed by three unequal sides and three unequal angles.
- An isosceles triangle is a made by two equal sides, and hence two equal angles.
- An equilateral triangle is formed by the equal sides and equal angles.
- A right-angled triangle has only one right angle in a triangle. The side opposite to the right angle is known as the 'hypotenuse'.

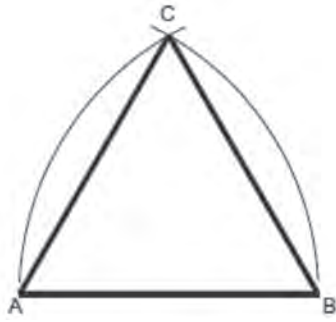

Fig.6.15: Drawing equilateral triangle

Problem 10

Construct an equilateral triangle, if one of the sides is given.

Solution: (Fig.6.15)

1. Using a scale draw a line AB equal to the given length of the side.
2. Place compass needle at point A and open it to the radius equal the length of side AB and draw an arc as shown in the figure.
3. Similarly place the compass needle point on B, and without changing the radius, draw another arc to cut the first arc at point C.
4. Join AC and BC. Triangle ABC is an equilateral triangle.

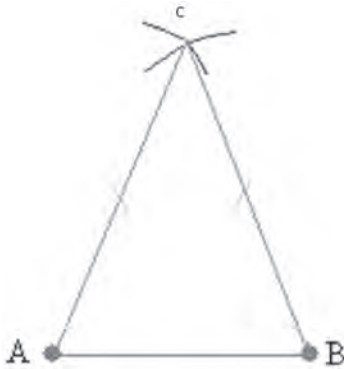

Fig.6.16: Drawing isosceles triangle

Problem 11

Construct an isosceles triangle.

Solution (Fig.6.16)

1. Using a scale draw a line AB to a given length.
2. Open a compass more than the length of AB, place the compass needle at point A and draw an arc as shown in figure.
3. Keeping the same compass opening, again place the compass needle at point B and draw an arc, and intersect the previous arc at point C.
4. Join AC and BC.
5. ABC is the isosceles triangle in which $AC=BC$

Problem 12

Construct a scalene triangle with side lengths as 6cm, 5cm and 4cm, respectively.

Solution (Fig.6.17)

1. Using a scale draw a 6cm line. Mark one of the end as A and the other B as shown in the figure.
2. Set the compass to a radius of 5cm which will be equal to the second side of the triangle.

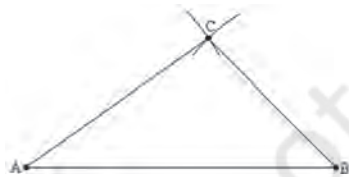
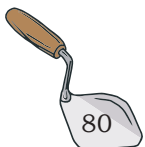

Fig.6.17: Drawing scalene triangle



3. Place the compass needle at point A and draw an arc above the line.
4. Set the compass to a radius of 4cm which will be equal to the third side of the triangle.
5. Place the compass needle at point B and draw an arc above it so as to intersect the previous arc at point C.
6. Join AC and BC to form a triangle ABC.

The Quadrilateral

Definitions

A figure bounded by four straight sides is called quadrilateral.

- A quadrilateral having four sides of equal length and all the four angles as right angle is called square.
- A quadrilateral with its opposite sides of equal length and all the four angles as right angle is called rectangle.
- A quadrilateral with its opposite sides of equal length and parallel is called parallelogram.
- A quadrilateral with all four equal sides is called rhombus.
- A quadrilateral with one pair of opposite sides as parallel is called trapezium.
- A quadrilateral having all unequal four sides and angles is known as trapezoid.

Problem 13

Construct a square, the length of the side is given.

Solution: (Fig.6.18)

1. Using a scale draw the side BA equal to the given length.
2. Make an angle of 90 degrees or erect a perpendicular from point B.
3. Mark the point C on the perpendicular line so that line BC is equal to the line BA equal to the given length.
4. Open the compass equal to the length of the side of the square, with needle point at A and C, draw arcs to intersect at point D.

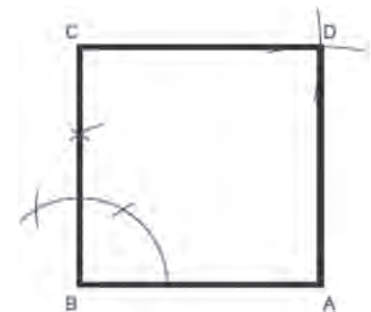

Fig.6.18: Drawing a square

- Join CD and AD. Thus, the quadrilateral ABCD formed is the required square having all the sides equal and all the angles as right angles.

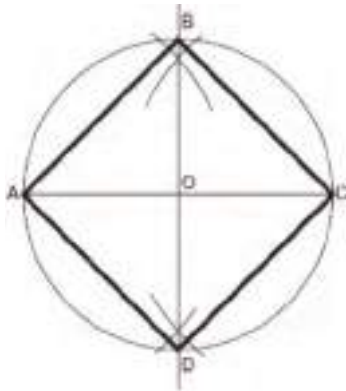

Fig.6.19: Drawing a square given diagonal

Problem 14

Construct a square, the length of diagonal given.

Solution: (Fig.6.19)

- Using a scale draw a diagonal AC equal to a given length.
- Bisect AC so that O is midpoint of the diagonal. Extend the bisecting line.
- Set the compass to radius OA (OC) and with needle point at centre O, draw a circle so as to cut the bisecting line at point B and D respectively as shown in figure.
- With the help of a scale join the points on the circle and form the quadrilateral ABCD.
- Therefore, the quadrilateral ABCD is the required square.

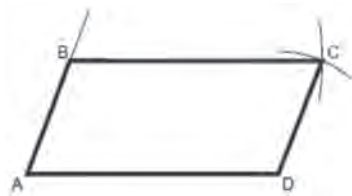

Fig.6.20: Drawing a parallelogram

Problem 15

Construct a parallelogram, of which two sides and an angle are given.

Solution: (Fig.6.20)

- Using a scale draw AD equal to the length of one of the given sides.
- With the help of a protractor construct the known angle at point A and extend the angle line.
- Using a compass or scale mark off AB equal in length to the other given side.
- Open the compass equal in radius to AD and with compass needle at point B draw an arc.
- Open the compass equal in radius to AB and with compass needle at D, draw an arc equal in radius to AB which intersects the previous arc at point C.
- Join point B with C and point C with D. Thus ABCD is the required parallelogram.

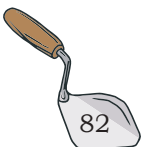

Problem 16

Construct a trapezium, given lengths of the parallel sides, the perpendicular distance between parallel and one angle.

Solution: (Fig.6.21)

1. Using scale or ruler draw AB equal to the length of one of the parallel sides.
2. Open the compass equal to the given perpendicular distance, construct the parallel line by drawing arcs from point B and A, respectively.
3. From point B construct the given angle so as to intersect the, parallel line in point C.
4. From point C mark off the other given length of parallel side equal to CD. Join DA.
5. Therefore ABCD is the required trapezium.

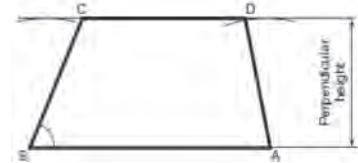

Fig.6.21: Drawing a trapezium

Problem 17

Construct a rhombus when the diagonal and the length of the sides is given.

Solution: (Fig.6.22)

1. Using a scale draw the line AC equal to the diagonal.
2. Open compass equal in length to the sides and from points A and C draw intersecting arcs, which intersects at points B and D respectively.
3. Join AB, BC, CD, and DA.
4. Thus, ABCD is the desired trapezium.

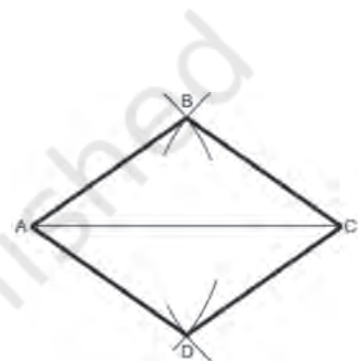

Fig.6.22: Drawing a rhombus

Polygons

Definitions

A plane figure bounded by more than four straight sides is called a polygon.

- A plane figure bounded by five sides is called a pentagon.
- A plane figure bounded by six sides is called an hexagon.
- A plane figure bounded by seven sides is called an heptagon.
- A plane figure bounded by eight sides is called an octagon.

- A plane figure bounded by nine sides is called a nonagon
- A plane figure bounded by ten sides is called a decagon.

If all sides of polygon are equal it is called a regular polygon. Therefore, the regular polygon will have all its exterior angles equal and also all interior angles equal.

Problem 18

Construct a hexagon; the length of the sides is given.

Solution: (Fig.6.23)



Fig.6.23: Drawing a hexagon

1. Open the compass to a radius equal to the length of the side and draw a circle,
2. Do not change the opening of the compass, take any point on the circumference of the circle and mark the radius around the circle six times. You will finish exactly at the same point on the circumference where you started if the construction is accurate.
3. Using a scale join the six points to form a regular hexagon as shown in the figure.

Problem 19

Construct any regular polygon; the length of a side is given.

Solution: Method 1 (Fig.6.24)

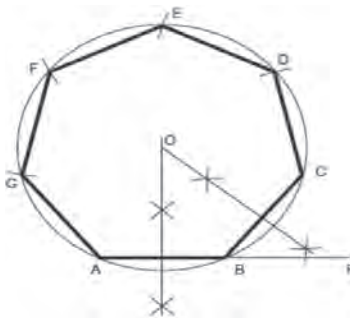
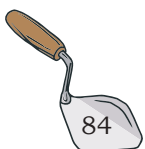

Fig.6.24: Drawing a polygon

1. Using a scale draw a line AB equal in length to one of the given sides. Extend the line AB to a point P.
2. The exterior angle of the polygon is calculated dividing 360° by the number of sides of the polygon. In this case regular polygon is a heptagon, therefore the exterior angle is $360^\circ / 7$.
3. At point B draw the exterior angle PBC. Mark off BC equal to AB.
4. Bisect the lines AB and BC. The bisectors intersect in point O as shown in the figure.
5. Open the compass equal to radius OA ($OB = OC$) and with centre O draw a circle.



6. Mark off the sides of the figure with the compass opening it equal to the side of the polygon from C to D, D to E, E to F, and F to G.
7. Join the points on the circumference and ABCDEFG is the required heptagon.

Solution: Method-2 (Fig.6.25)

1. Using a scale draw a line AB equal in length to one of the given sides. Extend the line from the point A.
2. Open the compass equal to radius AB, with needle point at A draw a semi-circle so as to meet the extended line BA at point P.
3. Divide the semi-circle into equal parts. The number of parts should be equal to the number of sides of polygon. This may be done by calculation ($180^\circ / 7$ for each arc) since in the example the regular polygon is heptagon.
4. Using a scale draw a line from point A to point 2 (for all polygons). This line thus forms a second side of the polygon.
5. Using a compass, bisect the lines AB and A 2 to intersect in point O as shown in the figure.
6. Open the compass equal to radius OB ($OA = O2$) and with centre O draw a circle.
7. Mark off the sides of the figure with compass opening equal to the side of the polygon from B to C, C to D, D to E, E to F, and F to G.
8. Join the points on the circumference and ABCDEFG is the required heptagon.

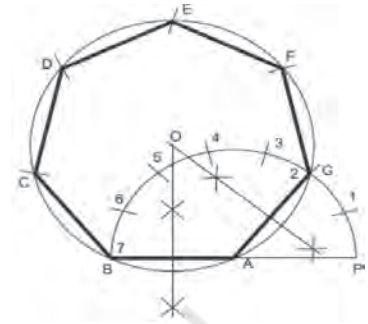

Fig.6.25: Drawing a polygon

Problem 20

Construct any regular polygon; the length of a side is given or general method of drawing any regular polygon.

Solution: Method-3 (Fig.6.26)

1. Using a scale draw a line AB equal to the given length of polygon.

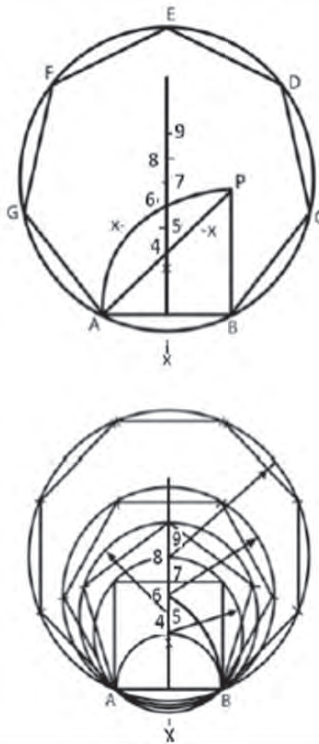

Fig.6.26: Drawing polygon

2. At point B of the line, draw a perpendicular BP and mark it off equal to AB the length of the side of polygon.
3. Join point A with point P to form straight line AP.
4. Open the compass equal to radius AB and with centre B draw an arc AP.
5. Draw the perpendicular bisector on the line AB and extend it so as to meet the straight line AP and arc AP in points 4 and 6 respectively.
6. Using a compass bisect the distance between point 4 and 6 in order to get the point 5.
7. Adjust the compass to radii as 4B, 5B and 6B and draw circles with centres as point 4, 5 and 6 and inscribe a square, pentagon and hexagon in the respective circles.
8. For inscribing heptagon and octagon, etc; and their respective circles, mark centre point 7, 8, etc; with 6-7,7-8,etc; equal to the distance 4-5 as shown in the figure.

Practical Activity

1. Make a list and poster showing important drawing instruments (freehand sketches) used for geometric constructions.

S.No.	Instruments used

Check Your Progress

A. Fill in the blanks

1. The understanding of plane geometry is pre-requisite for the proper use of _____.
2. A plane figure surrounded by _____ forms a triangle.
3. A scalene triangle is formed by three _____ sides and three _____.

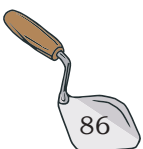

4. A figure bounded by _____ sides is called quadrilateral.
5. A quadrilateral with all _____ sides is called rhombus.
6. A plane figure bounded by more than _____ sides is called a polygon.
7. A plane figure bounded by _____ sides is called heptagon.
8. A plane figure bounded by _____ sides is called decagon.

B. State whether the following statements are true or false.

1. Bisecting the line means dividing the line into two equal parts.
2. If one line is perpendicular to another line, they intersect each other at 45° .
3. A triangle having all the three sides equal is called equilateral triangle.
4. A plane figure with more than five sides is called quadrilateral.
5. A quadrilateral with all four equal sides is called rhombus.
6. A quadrilateral with one pair of opposite sides parallel is called trapezium.
7. A plane figure bounded by eight sides is known as heptagon.
8. A plane figure bounded by nine sides is called nonagon.

C. Answer the following questions

1. Why geometric constructions important in making drawing?
2. Divide a straight line into seven equal parts.
3. List the steps making polygon having 10 equal sides.
4. Drawing tangents from a given point lying on the diameter of circle to the circle.

SESSION 2: TOOLS OF ENGINEERING DRAWING

Engineering Drawing

A drawing is a graphical representation of a real object. Engineer express ideas on a paper through the medium of drawing. The use of a drawing is to explain the shape and size of a particular object by means of lines.

For understanding a drawing, knowledge of the standard conventions, basic symbols and rules used on the different types of drawings is required.

Drawing Scale

A scale is used to draw and represent the actual size of real-life objects, such as the real size of a car, an airplane, for this we need drawings scale to represent

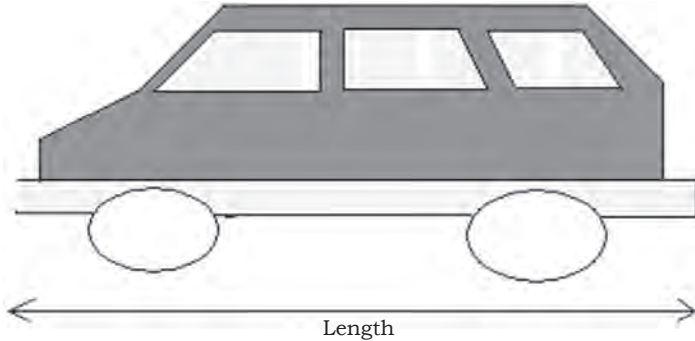

Fig.6.27: Drawing scale

the size like the one you see in Fig.6.27 of a van.

In real life, the length of this van may measure 6000 mm. It is suggested that, the length of print paper that one may use to draw this van should be a little bit less than 300 mm.

Since $6000/300 = 20$, you will need about 20 sheets of

copy paper to draw the length of the actual size of the van. In order to use just one sheet, you may use 1 mm on your drawing to represent 20 mm on the real-life object. We can write this situation as 1:20 or $1/20$ or 1 to 20.

It may be noted that the first number always refers to the length of the drawing on paper and the second number refers to the length of the actual object.

The drawing scale is also called representative fraction (RF). It shows instantly the ratio of the size of the line on the drawing and the actual size. It can be said, that the ratio of numerator to denominator of the fraction is the ratio of drawn size to natural size of an object. RF of $1/20$ means that the actual size of the object is twenty times of the size of the drawing of same object.

The scale of 1:1 (read as one-to-one) shows the object has been drawn to true size. A scale of say 2:1 (read as two-to-one) informs that the object has been enlarged twice its true size in the drawing. A scale of 1:2 (read as one-to-two) shows that the object has been reduced to its half size, etc.

Dimensions of Drawing Sheets

The common paper sizes for technical drawings are known as A-FORMATS. In the A-Format series, the largest size is A0. The size of an A1 paper is half the



size of A0 while A2 is half the size of A1 and so forth. Higher order paper size (which is always smaller in size) is obtained by simply halving the preceding size along its longer side. Size of A4 is found to be the smallest paper size in technical drawings. The A format paper sizes are shown below:

Designation	Dimensions in mm
A0	841 × 1189
A1	594 × 841
A2	420 × 594
A3	297 × 420
A4	210 × 297

Basic Line Types

The basis of any drawing is a line. The use of a right type of line make a correct drawing. Table shows some basic types and thickness of lines used for various purposes (for more lines refer to BIS). Each line represents a definite aim and it should not represent anything else.

Type of lines	Appearance	Name according to application
Continuous thick line		Visible line
Continuous thin line		Dimension line Extension line Leader line
Dash thick		Hidden line
Chain thin line		Centre line
Continuous thin wavy		Short break lines or irregular boundary lines – drawn freehand
Continuous thin with zig-zag		Long break lines
Short dashes gap 1, length 3 mm		Invisible or interior surfaces lines
Long chain thick at end and thin elsewhere		Cutting plane lines

Meaning of Lines

Visible or object lines represent features that can be seen in the current view.

Hidden lines explains the features which are not seen in the current view.

Center line explains symmetry, axis of symmetrical parts, centers of circles, path of motion.

Dimension, leader and extension lines shows the sizes and location of items on a drawing.

Cutting plane lines explains the place of an unreal cut which has been done, so that the interior of the item can be seen.

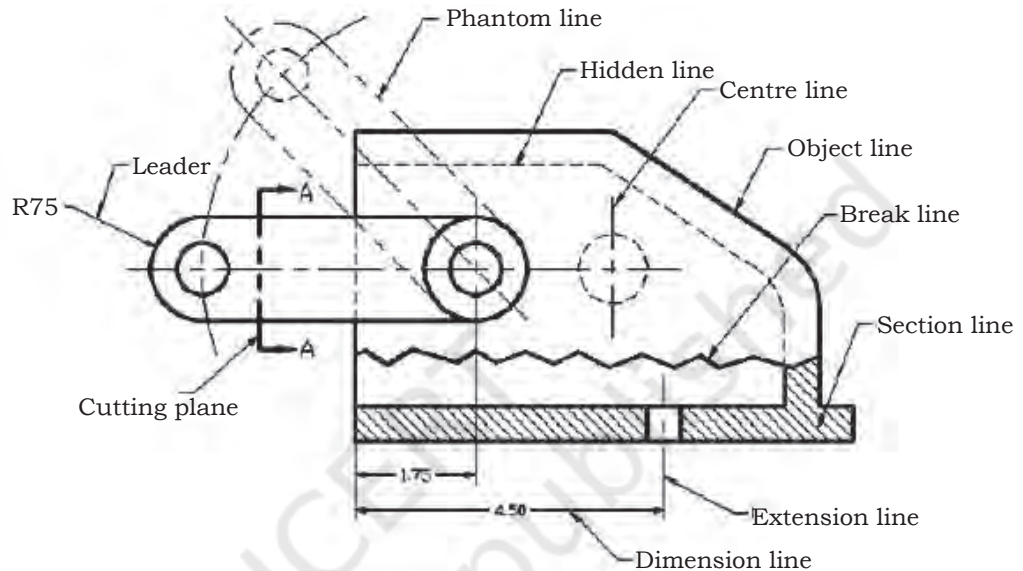

Fig.6.28: Line conventions in engineering drawing

Phantom lines indicate or show imaginary features, such as a moving position of a part.

Break lines explain imaginary cut where the interior of the object can be viewed.

Example: Line conventions in engineering drawing (Fig.6.28)

Projections

A projection is view considered to be drawn onto a plane, called as the plane of projection. Orthographic or multiview projections is made from an object developed by projectors from the object perpendicular to the planes of projection.

The concept of projection is used to display 3-D objects on 2-D media (paper, computer) graphically. The projection theory is based on line of sight and plane of projection.



Line of sight is an imaginary line of light between an observer's eye and an object.

Isometric projection

In isometric projection, all dimensions with the three axes are drawn to true size. Isometric projection is made when the three views of the object are seen for accurate presentation of the object.

The main advantage of isometric drawing is that it is easy to understand and the disadvantage includes the distortion in shape and angles as shown in Fig.6.29.

Orthographic Projections

In this projections, an object is presented in a unique way where more views are required. It is a parallel projection technique in which the parallel lines of sight are drawn perpendicular to the projection plane as shown in Fig.6.30. The number of views needed should be sufficient to represent the object completely and

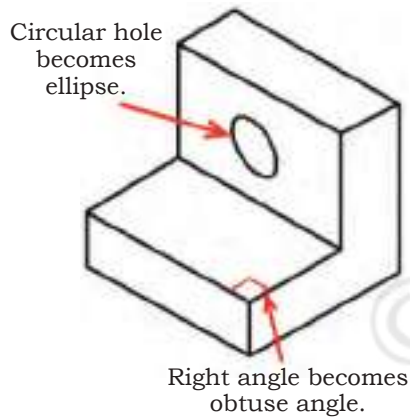

Fig.6.29: Shape and angle distortion in isometric drawing

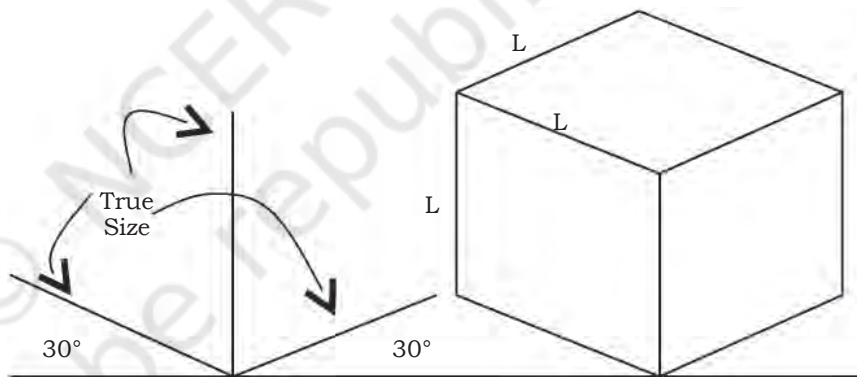

Fig.6.30: Isometric projection

conveniently, but it should be kept to the minimum. For all purposes, three views are completely sufficient.

- Engineering drawings usually prefer orthographic views rather than pictorial views.
- Orthographic views makes the record the shapes of an item correctly and completely.
- Orthographic view is a two-dimensional (2-D) drawing. It shows only one side of an object and two of its overall dimensions.
- A minimum of two orthographic views are required

to show the three dimensions of any object and therefore to describe its shape completely.

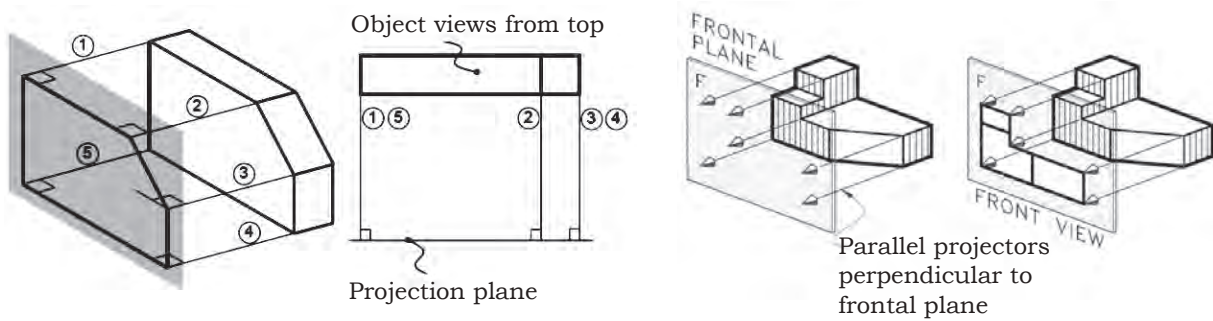

Fig.6.31: Orthographic projection

Some features of the object that do not directly appear on viewing the object from any specific direction (known as hidden details) are shown on the drawing as dotted lines.

Standard Orthographic Projections

Two standards are commonly in use in orthographic projection of drawings — the First Angle Projection and the Third Angle Projection. It should be noted that corresponding views are identical in both methods of projection except for their relative positions on the drawing paper.

The First Angle Projection

In here, the front view is the basis (reference) and the other views are drawn as ‘shadows’ of that view. That is, the left hand side view for instance is drawn on the right side of the front view. Similarly, the top view (plan) is drawn at the bottom of the front view, etc.

Projection	Symbol
First angle	
Third angle	

Fig.6.32: The symbols used for first angle and third angle projections used in engineering drawings.

The Third Angle Projection

In here, the front view is the basis (just as before) but the other views are drawn as ‘reflections’ of that view. The left hand side view is drawn on the left hand side of the front view. Similarly, the top view (plan) is drawn at the top of the front view. The symbols for first and third angle projections are shown in Fig.6.32.

Example: First angle projection

In first-angle projection, the item or object is kept in



front of the image planes, and the views are created by projecting to the image plane situated at the back.

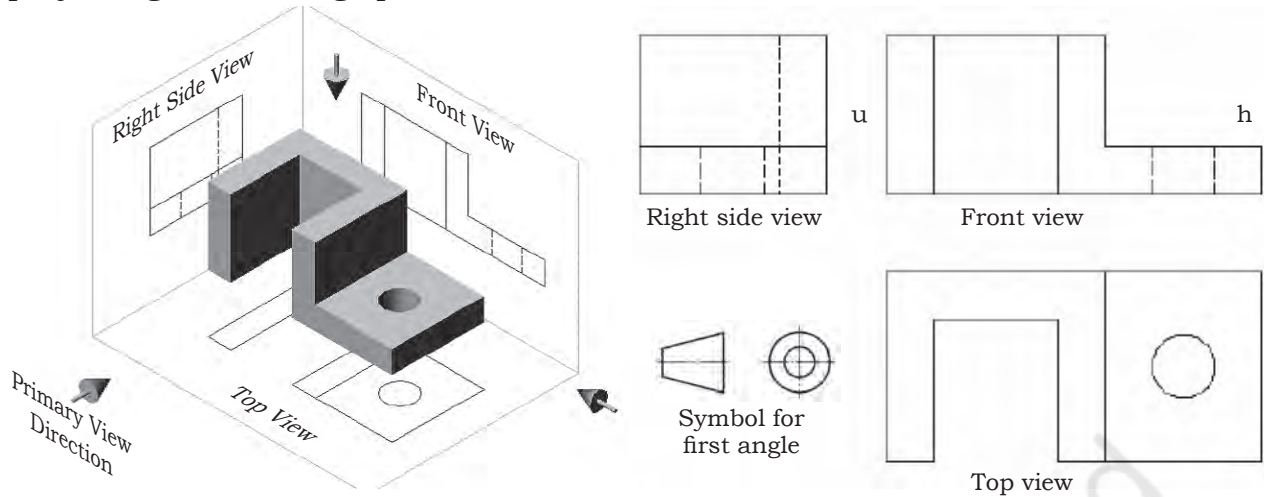

Fig.6.33: First angle projection

Example: Third angle projection

In third-angle projection, the image planes are kept in between the object and the observer. The views are created by projecting the image plane in front of the object.

Dimensioning

For making of machine components, all the relevant dimensions should be shown on the drawing. The practice is that any dimension is shown only once in that view in which it appears more explicitly. For this reason all the main dimensions are kept in the front view. Repetitions are avoided if not necessary. To keep the drawing clean, it is advised to put all the dimensions outside the drawing, except where and when this is unavoidable.

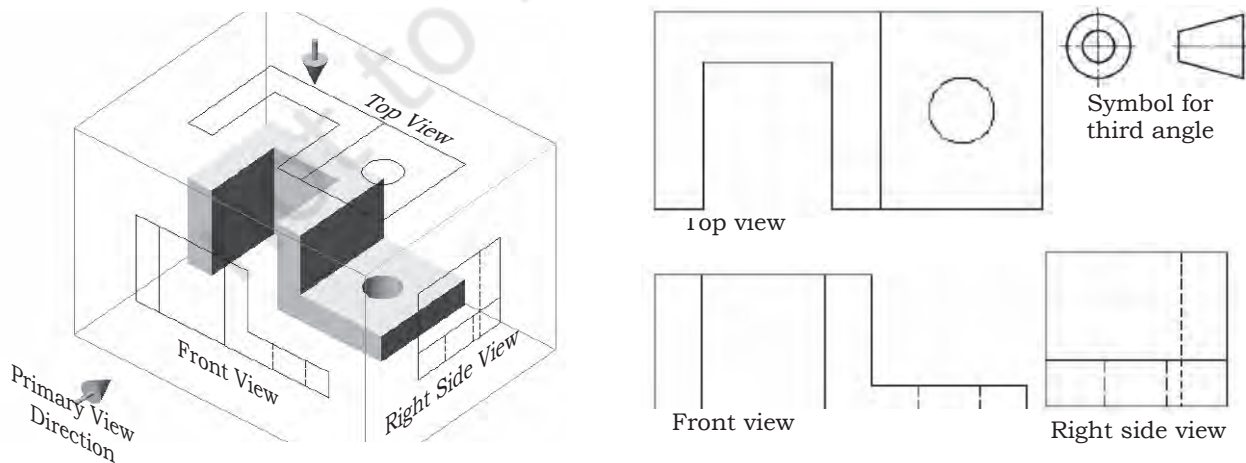

Fig.6.34: Third angle projection

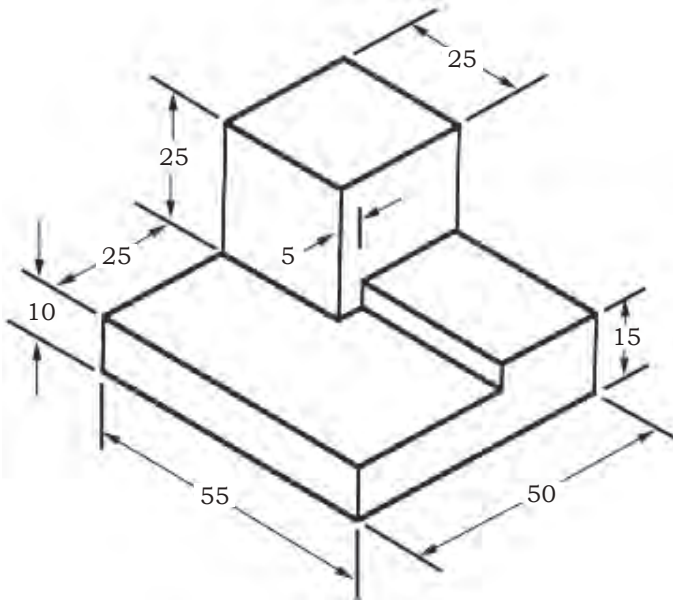

Fig.6.35: Dimensioning of the object

The dimensioning of the object of the isometric drawing is shown in Fig.6.35. As a thumb rule for dimensioning, make an object and dimension in the proper useful way. Dimensions should be drawn completely as per needs by the draftsman or technician.

Repeatedly measurement from one point to another point may lead to inaccuracies. It is always appropriate to measure dimensions from one end to other points. It is useful to choose the placement of the dimension in the order so that machinist would develop the part of product easily.

General Hints on Dimensioning

- Use common sense as per need and depend on circumstances.
- All linear dimensions are considered to be in millimetre in metric system.
- Show full size dimensions regardless of the scale used in the drawing.
- Dimension in a manner that makes it unnecessary to calculate any required size information.

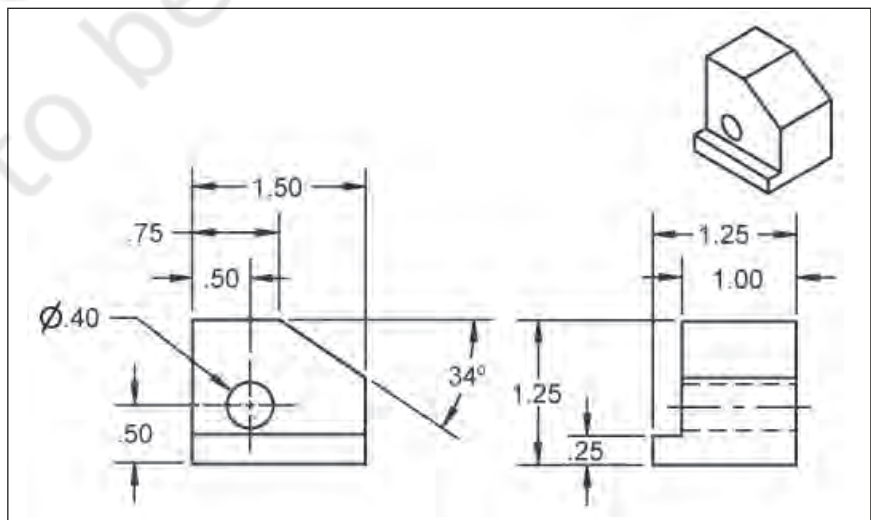

Fig.6.36: Dimensioning of 2-dimensional drawing



Drawing Sheet Layout

Standard layouts of drawing sheets are specified by the various standards organisations. Fig.6.37 shows layout of a specific drawing sheet, showing the drawing frame with title block, parts list and the space for orthographic projections.

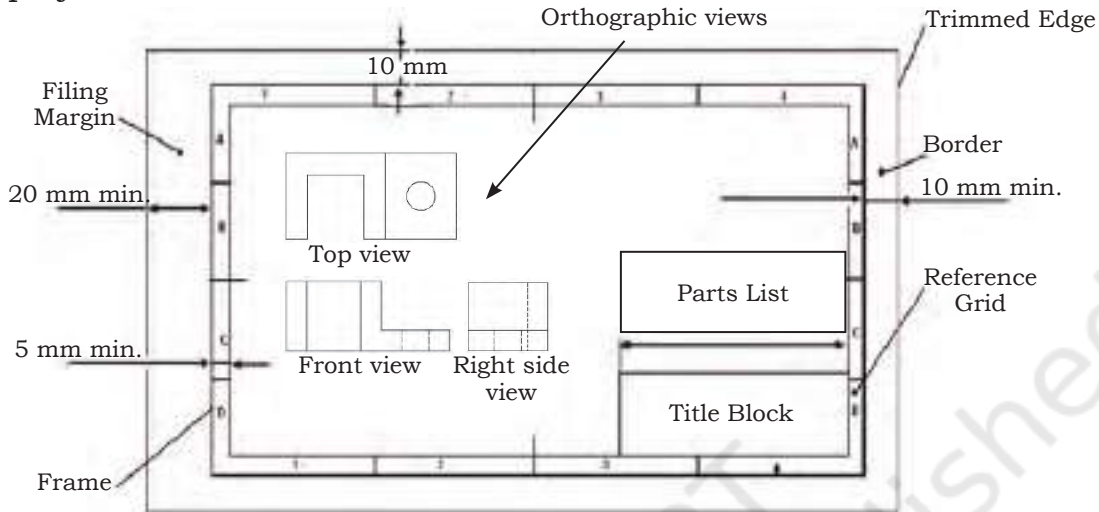

Fig.6.37: Layout of drawing sheet

Title Block

In engineering drawing, a Title Block is shown at the bottom right-hand corner.

The Title Blocks are written in simple way for better understanding. The following information should be added in this box.

Title Block is normally the:

- name of the firm/School/College
- name of the object (Work piece)
- number of the drawing
- format of the paper used (paper size)
- scale used
- dimensioning unit (usually millimetres --- mm)

The format of title block may vary. A typical title block is shown below:

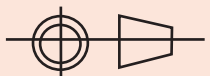
Projection: 	Scale: 1:10	Drawn: Kashiv	Remarks:	
	Dimension:	Group: Eng. & Tech		
	Date:	Checked: Saurabh		
PSSCIVE Bhopal	Name of Object: Knuckle Joint		Drg. No.	Format

NOTES

Parts List

It is an essential component in any assembly drawing. It is generally drawn above the Title Block. The Parts Lists are shown also in the Title block. The width of the parts list is same as the Title Block, i.e. 180 mm. The height depends on the number of items to be included. The following information is usually included in the Parts List;

- A. Part reference number
- B. Name of the part
- C. Number of parts required in an assembly
- D. Material used to manufacture the part
- E. Indication of standard or dimension
- F. Drawing number

A	B	C	D	E	F
Ref. No.	Name of part	No. Reqd.	Material	Standard/ Dimension	Drg. No.

Spacing of Views

Spacing of views on drawing paper may be placed as such that the spaces between the views and the limits of the drawing space are roughly equal (horizontally and vertically).

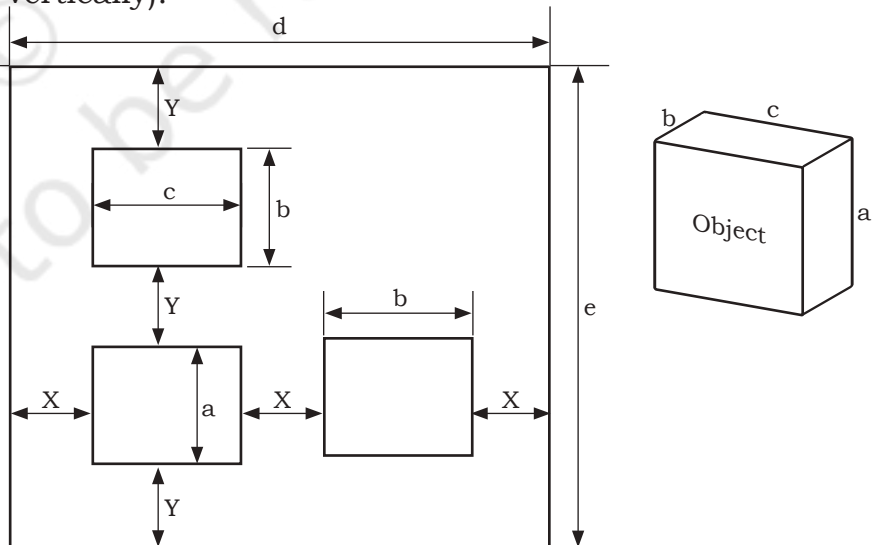
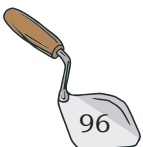

Fig.6.38: Spacing of views



Steps

1. Decide on the views to be drawn (i.e. front view, left hand side view and top view).
2. Determine the maximum dimensions of the various views to be drawn.
3. Determine the required space, based on the scale to be used, both along the horizontal and vertical directions.
4. Divide the “free space” into three equal portions, both horizontally and vertically. This determines X and Y as shown in the Fig.

Horizontal Free Space = (Horizontal Drawing Space) – (Occupied Space) = $d - (c + b)$

Horizontal spacing (X) = (Horizontal Free Space) / (Number of Spaces) = $\{d - (c + b)\} / 3$

Vertical Free Space = (Vertical Drawing Space) – (Occupied Space) = $e - (a + b)$

Vertical spacing (Y) = (Vertical Free Space) / (Number of Spaces) = $\{e - (a + b)\} / 3$

Reading Drawings

Technical drawings are used to visualise the product to be manufactured, built or assembled. A technical drawing explains shape, dimensions, and materials of construction and final shape of the material being created. For reading and understanding of a drawing, the Assistant mason needs to have some know-how of engineers and draughtsmen use dimensions, lines and notes to communicate the ideas on a sheet. They are imagined or drawn to help with the understanding the necessary information required to make and assemble an object regardless of its complexity. It is important that the assistant mason is able to read the drawings.

Steps for Reading Construction Drawing

1. Firstly, make sure it is the right drawing you are reading, see the name and part no. of the drawing.
2. Look at the Title Block on the drawing which is shown in the lower right of the drawing. The Title Block contains the information about the name of

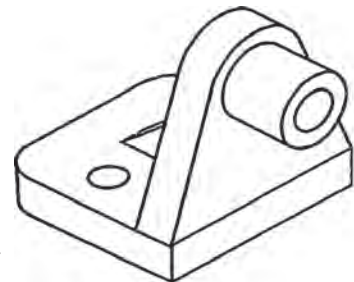

Fig.6.39: Construction drawing

NOTES

- the person who has drawn it, checked it, name of the firm or the institute, drawing number, part number, projection angle and the scale of the drawing. This will help you to know the component's information.
3. There are different types of lines which are used in drawings. Each line has a specific meaning and it must be understood to interpret a drawing correctly.
 4. Pictorial drawings are frequently used to show how an object should appear after it is manufactured. Pictorial drawings are used for simple objects.
 5. For a more critical object, as shown in Fig.6.28, complete description in a pictorial drawing becomes very difficult to show. In this case, it is common practice to prepare orthographic drawings. These drawing are prepared to describe the object fully.
 6. Orthographic drawings are made by parallel projections and include 2-dimensional multi-view drawings of the object. These consist of a front view, top view and the side view. Usually three views are sufficient to describe the project. However, any complex product may require as many as six views (top, front, left side, right side, back, and bottom).
 7. Check the places of the views shown in Fig.6.40. Person should understand orthographic drawings. As per practice, the top view is placed above the front view and the right-side view is placed to the right of the front view. If additional views are needed, the left side is always drawn to the left of the front view and the bottom is drawn below the front view. Placement of the back view is flexible; it is usually drawn to the left of the left-side view. When understanding the different orthographic views, a pictorial sketch should be prepared.
 8. In the drawing, dimensions of width and height of the object can be seen in the front view. The drawing of the top shows width and depth, and the side shows height and width.



9. Section views show the hidden features of an object so that a workshop technician can completely understand inside and outside details.
10. The dimensions provided in and around the projection views indicate measurements and the complete size. Usually, there are the projection and dimension lines.
11. Projections lines are drawn in alignment with edges of the object. Projections line are used to show the width of the indicated section.
12. Dimension lines are drawn from one projection line to another with arrowheads touching each projection line. Measurements are written on dimension lines to describe the size.
13. Look at symbols on the drawing. Identifying them is important when you are reading measurement.
14. Special precaution should be taken while handling the drawings. When drawings are not being used, keep them on a proper place or in another assigned place of storage. Drawings are integral part of construction and are difficult to replace if lost or damaged.

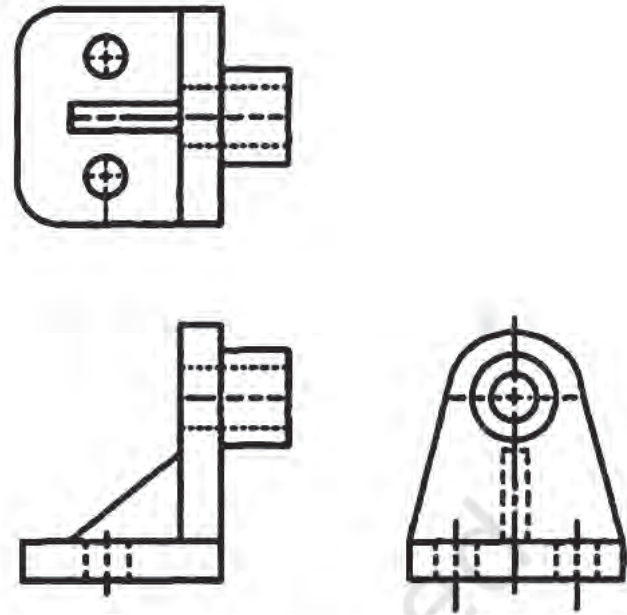

Fig.6.40: Orthographic views

Practical Activity

1. Make a list of drawing instruments used for geometric constructions

S.No.	Instruments used

NOTES

2. Prepare a poster showing six orthographic views of an object.

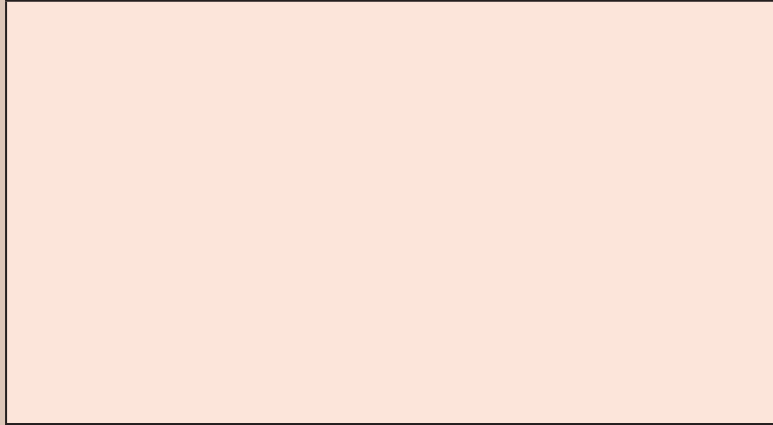

Check Your Progress

A. Fill in the blanks

1. A drawing is a _____ representation of a real object.
2. Engineering drawings do not portray the objects the way they _____ to the eye.
3. A scale has no _____ as it is simply a ratio.
4. The scale of 1:1 implies the object has been drawn to _____ size.
5. Hidden lines represent features that can not be seen in the _____ view.
6. _____ lines are drawn in alignment with edges of the object.
7. Line of sight is an imaginary ray of _____ between an observer's eye and an object.
8. Plane of projection is an imaginary _____ on which the image is created.
9. In isometric projection, all dimensions along all the _____ are drawn to _____ size.

B. State whether the following statements are true or false

1. An A4 paper size has dimensions of 297×420 mm.
2. Break lines are used to represent imaginary cut, so that the interior of the object can be viewed.
3. A scale of say 2:1 implies that the object has been enlarged twice its true size.
4. In diametric projection, all dimensions with two axes are drawn to true size.
5. In isometric projection, all dimensions along all the three axes are not drawn to true size.
6. Orthographic views help to record the shapes of objects exactly and completely.
7. A nonagon is a plane figure bounded by nine sides.



8. In the First Angle Projection the front view is the basis (reference) and the other views are drawn as 'shadows' of that view.
9. In every engineering drawing, a Title Block is included at the bottom right-hand corner.
10. Spacing of views on the drawing paper is not important.

C. Answer the following questions

1. Why are engineering drawings important in manufacturing and assembly?
2. What are the steps required for making engineering drawing?
3. What is the importance of scale in making engineering drawing?
4. Differentiate between diametric and isometric projection.
5. Give the steps for reading engineering drawing.

SESSION 3: BUILDING AND BUILDING DRAWING

A building is considered as the three dimensional shape or form in the space, resting on the earth secured to the earth by foundation for stability. It consists of architectural space and structure for enclosing the space.

Planning, designing, drawing, estimating, construction, occupation, maintenance and preservation are various stages related to the buildings. Building drawing is a result of planning and designing for a specific type of building — it is a graphic representation by means of the shape and size of the proposed construction by means of lines, dimensions, notes, schedules, statement of areas etc.

Building Drawing

Drawing is the universal graphic language of architects and engineers. It has got its own grammar consisting of projectors and projections, orthographic and conical projections, use of different types of lines, symbols, abbreviations, dimensioning. The Assistant Mason is expected to have know-how to draw different views — plan, sections, elevations, read a drawing and use set

NOTES

of drawings for estimating and construction purpose. Drawing is a tool to express all ideas about the proposed construction of building.

Building Plan

In building drawings, views projected of horizontal planes and observed from the top is known as a plan, shown in Fig. 6.41.

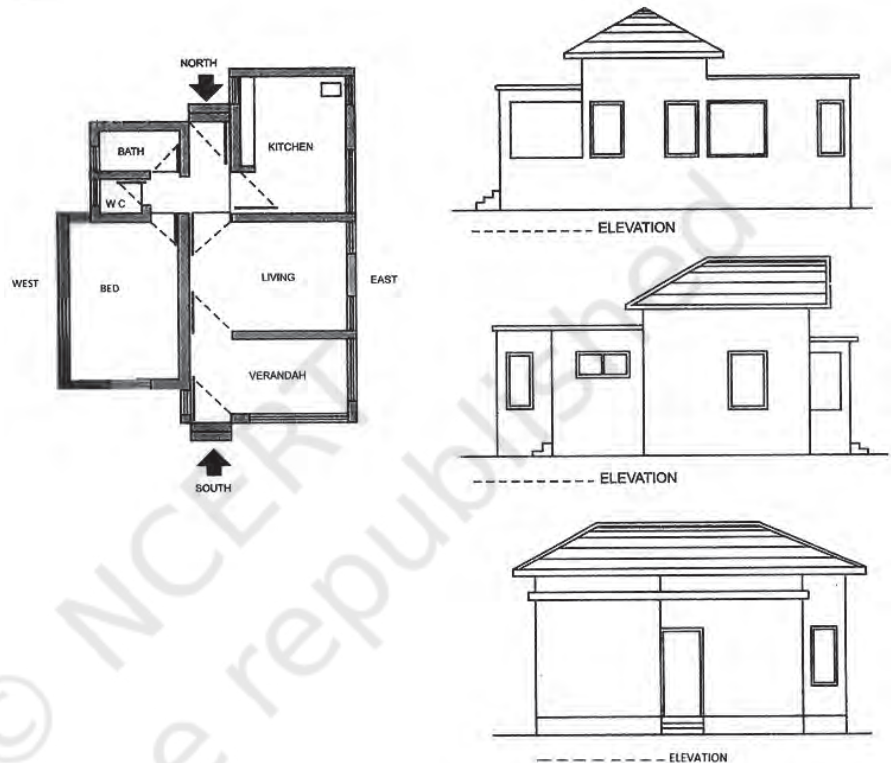

Fig.6.41: Plan and Elevation of Building

Elevation: Views projected to vertical plane, such as front size and rear view are called elevation. It is also termed as from elevation, side elevation and rear elevation.

Checklist for a Building Plan

Building plan should be checked with the list given below.

1. Dimensions the outside wall, rooms, passage, window and door and centre line, thickness of masonry, arrowheads for dimension line
2. Door, window symbols



3. Staircase
4. Floor level
5. Symbols for kitchen, sinks, WC bath, washbasin
6. Rooflines
7. Section lines
8. Built in cup board
9. Types for rooms
10. Floor finished schedule
11. Floor, plant, title and scale

Sections: In section, cutting plane or line has been drawn to give the internal details of the building vertically. It shows materials used, superstructure wall, plinth height, flooring, roof details, etc.

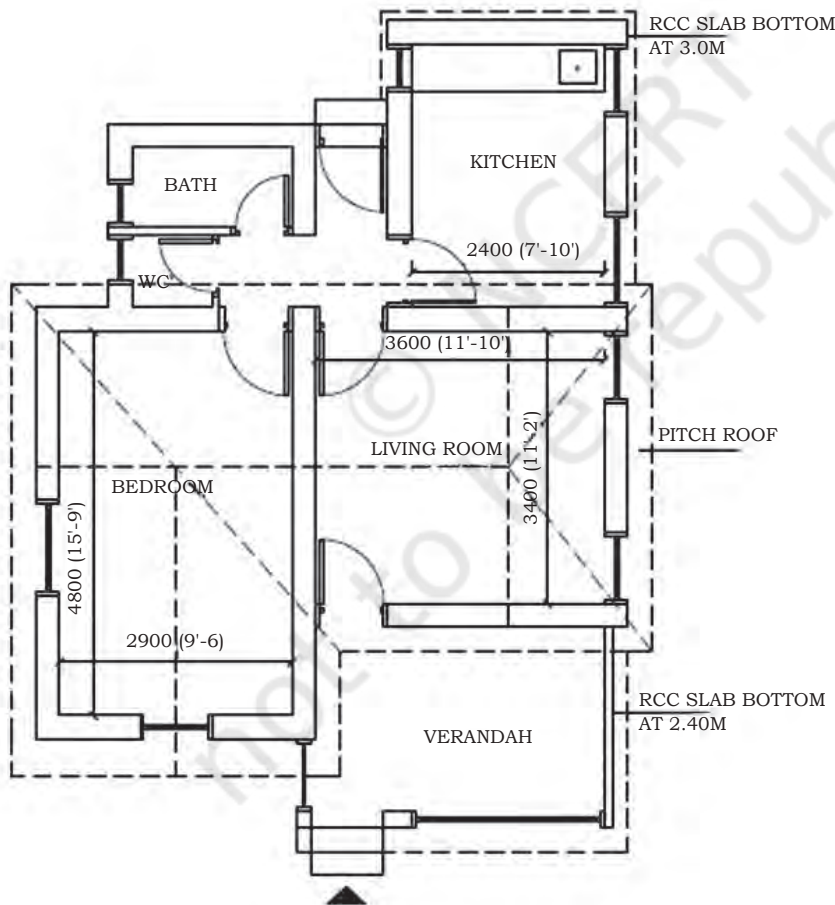

Fig.6.42: Sections

NOTES

Check Your Progress

A. Fill in the blanks

1. The size of A1 drawing sheet is _____ mm.
2. Tee square is used to draw _____ lines.
3. Compass is used to measure _____.
4. In third angle method projection, top view lies _____ of front view.

B. Answer the following questions

1. Explain different types of lines used in a building drawing.
2. Draw a neat sketch of the mini drafter.
3. Sketch the symbols for 1st and 3rd angle method projection.
4. Which points are to be noted in building plan, elevation and section?

C. Write short notes on

1. Building drawing
2. Set squares
3. Engineering drawing
4. Orthographic projection
5. Dimensioning

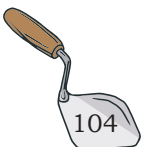

Unit

7



Foundation Works



17922CH07

BUILDING FOUNDATION

Foundation is the lowest, artificially prepared parts of a structure which is in direct contact with the ground and which transmits the loads of the structure to the ground. The purpose of foundation is to transmit the anticipated loads safely to the soil.

Advantages of foundation

1. To distribute the total load coming from the structure over larger area of soil
2. To support the structure
3. To give stability to the structure
4. To prepare a level surface for concreting and masonry work

Footing

The lowermost portion of the foundation which is in direct contact with the sub-soil is called the footing.

Types of Foundation

Depending upon their nature and depth, the foundations are —

- a) Shallow foundation
- b) Deep foundation

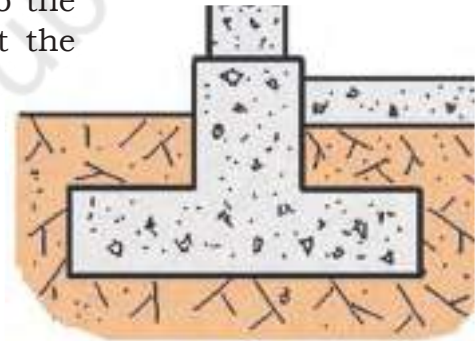

Fig. 7.1: Shallow Foundation

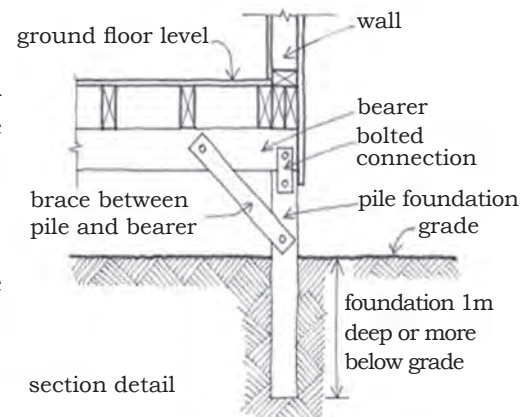

Fig. 7.2: Deep Foundation

Shallow Foundation

This is the most common type of foundation and can be laid using open excavation by allowing natural slopes on all sides. This type of foundation is practicable for a depth of about 1-1.5 m and is normally convenient above the water table. The base of the structure is enlarged or spread to provide individual support (Width is greater than its depth).

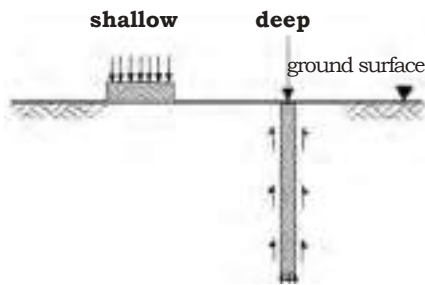

Fig. 7.3: Shallow and Deep Foundations

Types of shallow foundations

- a) Wall footing
- b) Isolated footing
- c) Combined footing
- d) Inverted footing
- e) Continuous footing
- f) Cantilever footing
- g) Grillage footing
- h) Mat or raft foundation

Deep Foundation

These foundations carry loads from a structure through weak compressible soil or fills onto the stronger and less compressible soils or rocks at depth. These foundations are in general used as basements, buoyancy rafts, cylinders, shaft and piles. (Depth is greater than its width)

Types of deep foundations are classified as

- a) Basements
- b) Buoyancy rafts
- c) Well and caissons
- d) Shaft foundations
- e) Pile foundations

The causes for the failure of foundations

- a) Non-uniform settlement
- b) Horizontal movement of the soil
- c) Alternate swelling and shrinkage
- d) Lateral pressure due to lateral movement of earth
- e) Action of weathering agencies
- f) Lateral escape of the soil beneath the foundation of structure
- g) Roots of trees and shrubs

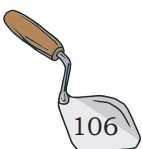

SESSION 1: EXCAVATION

NOTES

Excavation is the preliminary activity of the construction project. It starts from the pits for the building foundations and continues up to the handing over of the project.

Tools required

The following are the materials used for the earthwork for foundation.

1. Spade
2. Kassi
3. Pick Axe
4. Crow Bar
5. Rammer
6. Wedge
7. Boning Rod
8. Sledge Hammer
9. Basket
10. Iron Pan
11. Line and Pins

Drawings required

1. Center line Drawing
2. Layout Plan

Size of foundation

- a) For Main Walls 4'0" Depth
- b) For Partition Walls 2'0" Depth

Points to be observed during excavation work

- Setting out of corner benchmarks
- Survey for ground levels
- Survey for top levels
- Excavation to approved depth
- Dressing of loose soil
- Making up to cut off level
- Constructing dewatering wells and interconnecting trenches
- Marking boundaries of the building
- Constructing protection bunds and drains

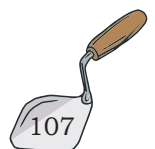

NOTES

Points to be observed during excavation

Excavation of soil is carried out manually or by excavation machinery, such as the JCB excavator machine, etc. Before excavation, it is necessary to know the soil strata; it is advised that trial pits in the construction site are made to check actual soil and rock strata.

The excavation and depth is decided according to the following guidelines on the site:

1. For Isolated footing — the depth to be one and half times the width of the foundation
2. For adjacent footings with clear spacing — less than twice the width (i.e.) one and half times the length
3. 1.5m in general and 3.5 m in black cotton soils
4. In construction site, open foundation pits for columns and trenches for coursed rubble (CR) Masonry was carried out. The maximum depth was upto 3m.

Procedure for making foundation

You have marked the line in the previous activity of mark centre line, similarly we have to do setting out or ground tracing. Ground tracing (Marking of line) is the process of laying down the excavation lines and center lines etc. on the ground before the excavation is started. The center line of the longest outer wall of the building is marked on the ground by stretching a string between wooden or mild steel pegs. Each peg may be projected about 25 to 50 mm from the ground level and 2m from the edge of the excavation. The boundary is marked with the lime powder. The center lines of other walls are marked perpendicular to the longer walls. A right angle can be formed by forming 3, 4 and 5 triangles. Similarly, outer lines of the foundation trench of each cross walls and are set out

Removal of Excess Soil

Estimate the excavated stuff to be re-utilised in filling, gardening, preparing roads, etc. As far as possible try to carry excavation and filling simultaneously to avoid double handling. Select and stack the required material in such a place that it should not obstruct other construction activities. The excess or unwanted material

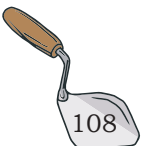

should immediately be carried away and disposed of by employing any of the following methods.

- Labour
- Tractor trolley
- Trucks

Quality checks for excavation

- Recording initial ground level and check size of bottom.
- Disposal of unsuitable material for filling.
- Stacking suitable material for backfilling to avoid double handling.
- Strata classification approval by competent authority.
- Dressing bottom and sides of pits as per drawing with respect to centerline.
- Necessary safety measures observed.

Quality checks for filling

- Recording initial ground level.
- Sample is approved for back filling.
- Necessary marking/reference points are established for final level of backfilling.
- Back filling is being carried out in layers (15cm to 20cm).
- Required watering, compaction is done.
- Required density is achieved.

Practical Activity

1. Carry out excavation activity for open trench as per foundation plan given below.

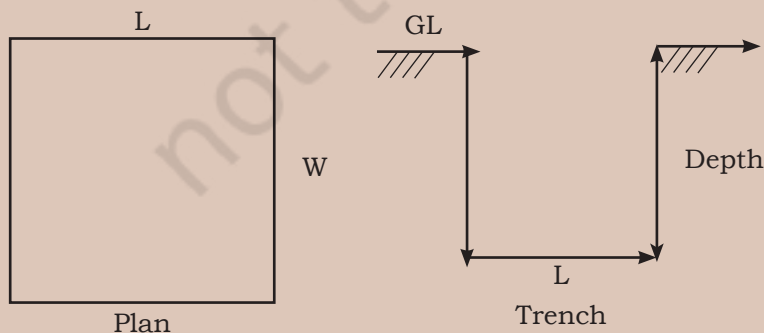

NOTES

SESSION 2: CONSTRUCT SPREAD FOOTING FOUNDATION

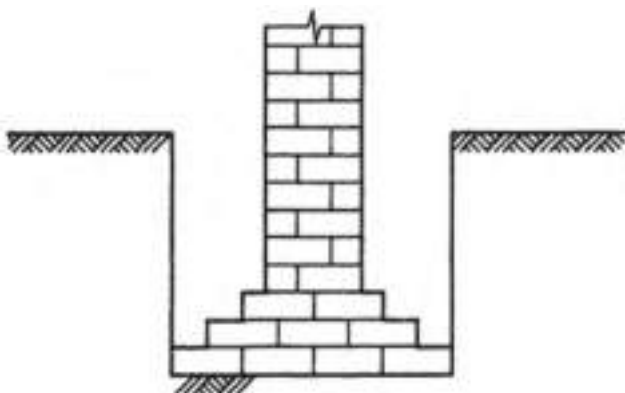

Fig.7.4: Spread Footing Foundation

In previous activities you have made the trench for a foundation, now we will construct a foundation in the trench. We will make a spread footing foundation to distribute the load of the wall over a larger area. Spread footing is applicable for load bearing structure. Mortar is used to fill the joints in brick masonry as it is the binding material. General a mixture of cement and sand are prepared in the ratio of 1:6.

Tools required

1. Mason square
2. Brick axe
3. Tape
4. Spade
5. Line dori
6. Plumb bob
7. Mortar pan (*Tagadi*)
8. Trowel

Material required

1. Bricks
2. Cement, sand and water

Procedure

1. Prepare a level of trench bed with plain cement concrete 1:5:10 and let it set for minimum 4 hours.
2. Bricks shall be soaked in the water properly before use properly
3. Cement and sand are placed on dry platform with 1:6 proportion
4. Add water as per required quantity in it and mix with the help of spade by turning side by side.
5. Now courses of the bricks are arranged as per given Fig. 7.4, in which first layer is three brick thick.
6. Mortar joints should be kept 10 mm thick.

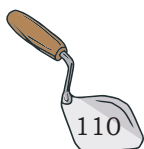

7. Over the third layer, second layer of two brick thick with cement mortar joints.(10mm) shall be arranged properly.
8. Brick shall be laid on their beds and with the frog upside.
9. Minimum offset shall be 1/4th of length of brick.
10. In each course, vertical joints should be broken.
11. After 4 to 6 course of 2 brick thick, next layer consist of one first course
12. Horizontal level shall be checked with line *dori*.
13. After construction of foundation is completed, curing is done for three days.
14. Curing is the processes of applying water on newly constructed brickwork, stone work, cement concrete, plastering etc.
15. It is important to cure fresh work as cement, when in chemical process with water heat is produced to gain the compressive strength for the further period so cement is kept wet at least one week after construction activity.

Practical Activity

1. Visit a construction site and observe the method of construction of different types of foundation.

Check Your Progress

A. Fill in the blanks

1. Foundation is the lowest _____ prepared part below the surface of the surrounding ground.
2. Excavation is the _____ activity of the construction project.
3. The bearing capacity of soil is used to _____ maximum load per unit area which the soil will resist safely without _____.
4. Deep foundations _____ loads from a structure through weak compressible soil or fills onto the _____ and less compressible soils or rocks at depth.

B. Write short notes on

1. Foundations
2. Brick footing tools
3. Shallow foundation and Deep foundation
4. Excavation of soil trench



Unit 1: Introduction to the Building Structure

B. Fill in the blanks

- | | |
|-----------|--------------------|
| 1. floor | 2. wall |
| 3. plinth | 4. super-structure |

D. Multiple choice questions

- | | |
|------|------|
| 1. c | 2. a |
| 3. d | 4. d |
| 5. d | 6. d |

Unit 2: Building Material

Session 1: Stones

B. Fill in the blanks

- | | |
|---------------------|---------------|
| 1. blocks | 2. stone |
| 3. high temperature | 4. weathering |
| 5. 2.4-2.8 | |

C. Multiple choice questions

- | | |
|------|------|
| 1. a | 2. d |
| 3. a | |

Session 2: Clay Products (Bricks, Tiles and Terracotta)

A. Fill in the blanks

- | | |
|-----------|---------------|
| 1. 19,9,9 | 2. substitute |
| 3. cement | 4. pattern |
| 5. cover | 6. covering |

C. Multiple choice questions

- | | |
|------|------|
| 1. a | 2. b |
| 3. c | 4. b |
| 5. a | |

Session 3: Cement and Lime

A. Fill in the blanks

- | | |
|----------------|--------------|
| 1. cement | 2. binding |
| 3. preparation | 4. resistant |
| 5. aggregate | |

C. Multiple choice questions

- | | |
|------|------|
| 1. d | 2. a |
| 3. b | |

Session 4: Ferrous and Non-ferrous Metals

A. Fill in the blanks

- | | |
|------------------------------|-----------------|
| 1. ores, quarrying or mining | 2. purest |
| 3. contain | 4. wrought iron |
| 5. 1.5% | |

C. Multiple choice questions

- | | |
|------|------|
| 1. a | 2. d |
| 3. a | 4. a |

Session 5: Mortar and Concrete

A. Fill in the blanks

- | | |
|----------------|------------|
| 1. material | 2. binding |
| 3. fine | 4. sand |
| 5. Gara | 6. mixture |
| 7. used, sorts | |

C. Multiple choice questions

- | | |
|------|------|
| 1. a | 2. c |
| 3. d | 4. a |

Session 6: Building Finishing Material

A. Fill in the blanks

- | | |
|-----------------|------------------|
| 1. mortar | 2. wall papering |
| 3. mortar | 4. walls |
| 5. coal tarring | |

C. Multiple choice questions

- | | |
|------|------|
| 1. a | 2. d |
| 3. c | 4. d |

Session 7: Miscellaneous Materials

A. Fill in the blanks

- | | |
|----------------------|---------------------------------|
| 1. viscous | 2. 10-12 mm |
| 3. PVC, polyethylene | 4. weight, strength, resistance |
| 5. light | 6. hard, excess |
| 7. bad | 8. two, single |
| 9. electric | |

C. Multiple choice questions

- | | |
|------|------|
| 1. a | 2. c |
| 3. b | 4. a |

NOTES

NOTES

Unit 3: Units of Measurements used in Civil Works

A. Fill in the blanks with appropriate measurement units

- | | |
|--------------------|-------------------|
| 1. cu.m. | 2. cu.m. |
| 3. cu.m. | 4. sq.m. |
| 5. sq.m. | 6. running metres |
| 7. number of steps | |

B. Multiple choice questions

- | | |
|------|------|
| 1. d | 2. b |
| 3. d | 4. d |
| 5. d | 6. d |
| 7. a | |

Unit 4: Handling of Basic Masonry Tools

A. Fill in the blanks

- | | |
|-----------------|------------------|
| 1. lift, mortar | 2. verticality |
| 3. dress | 4. cut |
| 5. conveying | 6. horizontality |
| 7. right angle | |

Unit 6: Building Drawing

Session 1: Basic Geometric Constructions

A. Fill in the blanks

- | | |
|----------------------------|-------------------------|
| 1. drawing | 2. three straight sides |
| 3. unequal, unequal angles | 4. four straight |
| 5. four equal | 6. four straight |
| 7. seven | 8. ten |

B. State whether the following statements are true or false

- | | |
|------|------|
| 1. T | 2. F |
| 3. T | 4. F |
| 5. T | 6. T |
| 7. F | 8. T |

Session 2: Tools of Engineering Drawing

A. Fill in the blanks

- | | |
|---------------------|---------------|
| 1. graphical | 2. look |
| 3. true zero | 4. light |
| 5. line | 6. Projection |
| 7. light | 8. path |
| 9. three axes, true | |



B. State whether the following statements are true or false

- | | |
|------|-------|
| 1. F | 2. T |
| 3. F | 4. F |
| 5. T | 6. T |
| 7. T | 8. T |
| 9. F | 10. F |

Session 3: Building and Building Drawing

A. Fill in the blanks

- | | |
|------------|---------------|
| 1. 594×841 | 2. straight |
| 3. angle | 4. at the top |

Unit 7: Foundation Works

Session 2: Construct Spread Footing Foundation

A. Fill in the blanks

- | | |
|---------------|-----------------------|
| 1. artificial | 2. preliminary |
| 3. bear | 4. carry and stronger |

NOTES

Acoustics: is the interdisciplinary science that deals with the study of all mechanical waves in gases, liquids, and solids including topics such as vibration, sound, ultrasound and infrasound.

Adhesion: is the ability of molecules/particles of a different substance to stick to each other.

Asbestos: is a naturally occurring mineral of the silica family and crystalline in structure. It is highly heat-resistant and can be woven into fabrics and is used in brake linings, fire-resistant and insulating materials.

BIS: the Bureau of Indian Standards (BIS) is the national Standards Body of India working under the aegis of Ministry of Consumer Affairs, Food and Public Distribution, Government of India. It is established by the Bureau of Indian Standards Act, 1986 which came into effect on 23 December 1986.

Bitumen: is a black or dark brown non-crystalline soil or viscous material having adhesive properties derived from petroleum crude either by natural or by refinery processes.

Building: is a man-made structure with a roof and walls standing more or less permanently in one place, such as a house or factory.

Buoyancy: is an upward force that fluids exerts on any object that is placed in them.

Ceramic: in general is any product made of natural clay, mixed in different proportions with water and sometimes organic materials, shaped, decorated, usually glazed, and hardened by heat.

Cohesion: is the ability of molecules/particles of a same substance to stick to each other.

Concrete: is the mixture of sand, cement, water, aggregates, in suitable proportion and with some admixtures added to the concrete to impart required characteristics.

Corrosion: is a phenomenon in which atmospheric oxygen in the air or water reacts with the metal to form oxides.

Corrugation: material shaped into a series of parallel ridges and grooves or like crest and trough of wave so as to give added rigidity and strength.

Course: laying of horizontal layer of brick or stone or concrete masonry units, etc., in a wall is known as course.

Curing: is wetting of concrete structure or concrete products as it helps in increasing the strength of the brick wall and durability of the concrete help in minimising the cracks and prevents shrinkage.

Dado: to make the walls smooth and prevent water absorption, Dado is applied for a height of three feet to seven feet especially in kitchens, toilets, hospitals, etc.

Durability: ability to resist elemental and natural forces of deterioration. This means how long material will survive with its intended or desired purpose.

Emulsion: is defined as the stable suspension of a hydrophobic substance in a Hydrophilic solvent with the aid of soap.

Forge: process that joins two pieces of metal by heating them to a high temperature and then hammering them together.

Foundation Settlement: is the movement of the foundation in downward direction due to the load of the entire structure over it, which thus displaces the soil below which results in the movement.

Foundation: is a sub-structure of building that transfers load of super-structure to the soil beneath.

Glaze: panels that are fixed into the aluminium or other types of frames which can be used as partition or curtain wall, doors and windows; glaze panels might be glass or other materials.

Guinting: a mixture of cement and sand with appropriate proportion which is used for repairing of concrete work which has been damaged due to bad workmanship or other environmental reasons.

Hard Strata: in engineering terms means soil layer, which has a

Levelling: is measurement of rise and fall of the surface of the earth.

Lining: is the support for remaining load of plaster which the wall could not support by itself.

Lintels: is a horizontal building component that lies across an opening and holds the weight of the structure above it. It is generally placed between two vertical supports.

Mortar: is a workable paste used to bind building blocks together. (Stones, bricks, and concrete masonry units). Mortar is a mixture of sand, a binder, such as cement or lime, and water.

Plinth: is normally the finished floor level of the ground floor. It is the level where you actually start seeing columns rising, from the floor, though columns penetrate up to footing. usually kept at 45° mm from existing ground level

Porcelain: ceramic products that have been baked at high temperatures to achieve vitreous, or glassy qualities such as translucence and low porosity.

Quarry: is a kind of open-pit mine from which rock or minerals are extracted.

Reinforcement: is used as reinforcement in concrete thus called reinforcement.

Shotcrete: is a mortar or concrete which is pneumatically projected or sprayed by a nozzle with high velocity on the prepared surface.

Sound insulation: is any material that impedes the transmission of sound waves.

Structure: is a series of connected, interrelated elements that form together a system that can resist a series of external load effects applied to it, which includes its own self weight, and provide adequate rigidity.

Sub-structure: structure constructed below ground level is termed as sub structure.

Super-structure: structure constructed above plinth level is termed as super structure.

Tar: is a substance derived from coal. It 's a thick liquid that holds high carbon content.

Thermal coefficient: is a value that determines how much material will expand or contract when the temperature increases or decreases.

NOTES

BIBLIOGRAPHY

IS : 12440 - 1988 Cr 4 *Indian Standard Specification for Precast Concrete Stone Masonry Blocks* (First Reprint March 1994) UDC 691'327-43 I

Building Material Textbook for Class XI, by Krishna Chandra Pandey, PSSCIVE, NCERT, New Delhi, 1999

Building Material Practical Manual for Class XI, by V K Tiwari, PSSCIVE, NCERT, New Delhi, 1999

Building Material by M.L. Gambhir, Tata McGraw—Hill Publishing Company Limited, New Delhi, 2012

Concrete Technology by M.L. Gambhir, Tata McGraw—Hill Publishing Company Limited, New Delhi, 1995

Building Construction by Sushil Kumar, Standard Publishers & Distributors, Delhi, 1997

Drainage Manual, Scientific Publishers, Jodhpur, 1995

Civil Engineering Drawing and Design by D.N. Ghose, C.B.S. Publishers & Distributors, New Delhi, 1987

Civil Engineering Drawing By R.S. Malik & G.S. Meo, New Asian Publishers, Delhi, 1997

Water Supply and Sanitation by Charanjit S. Shah, Galgotia Publishing Company, New Delhi, 1998

Building Drawing with an Integrated Approach to Built Environment, M.G. Shah, C.M. Kale & S.Y. Patki, Tata McGraw—Hill Publishing Company Limited, New Delhi, 2012

Building Maintenance by Director Vocational Education and Training, Bombay, 1994

The A to Z of Practical Building Construction and its Management by Mantri Institutes of Development and Research, Pune, 1998

